

City of Saltillo



Land Subdivision & Infrastructure Construction Standards

As Adopted by the Board of Aldermen

October 21, 2025



This Ordinance has been developed and enacted by the City of Saltillo Mayor and Board of Aldermen

Mayor Copey Grantham

Alderman Scottie Clark

Alderman Terry Glidewell

Alderman Brian Morgan

Alderman Craig Sanders

Alderman Sonya Hill Witcher

Municipal Attorney

Mr. Chris Evans

Municipal Clerk

Mrs. Mary Parker

*Developed in partnership through
the Lee County Council of
Governments*

Strong Partnerships
Strategic Planning
Sustainable Future



Council of Governments

TABLE OF CONTENTS

CHAPTER 1: LAND SUBDIVISION	7
PART 1 - ADMINISTRATION	7
1.1.1. PURPOSE AND AUTHORITY	7
1.1.2. DESIGNATION OF ADMINISTRATOR	7
1.1.3. MAJOR SUBDIVISIONS	7
1.1.4. MINOR SUBDIVISIONS	7
1.1.5. FEES	7
1.1.6. DEFINITIONS	8
PART 2 – PROCEDURES AND APPROVALS	8
1.2.1. PRE-APPLICATION CONFERENCE AND APPLICATION SUBMISSION	8
1.2.2. PRELIMINARY PLAT	8
1.2.3. PRELIMINARY PLAT APPROVAL	9
1.2.4. CONSTRUCTION PLANS	9
1.2.5. CONSTRUCTION PLAN APPROVAL	10
1.2.6. IMPROVEMENT SCHEDULE REQUIRED	10
1.2.7. INSPECTIONS REQUIRED	10
1.2.8. FINAL PLAT	11
1.2.9. FINAL PLAT APPROVAL	15
1.2.10. CONDITIONS OF APPROVAL	15
1.2.11. VARIANCES	15
PART 3 – ACCEPTANCE AND MAINTENANCE	15
1.3.1. ACCEPTANCE	15
1.3.2. APPEALS	16
1.3.3. UNLAWFUL ACTS	16
1.3.4. PENALTIES OF VIOLATIONS	16
CHAPTER 2: STORMWATER MANAGEMENT	17
PART 1 – GENERAL REQUIREMENTS	17
2.1.1 PURPOSE	17
2.1.2. METHODS	17
2.1.3. STORMWATER RETENTION AND DETENTION	18
PART 2 – STORMWATER POLLUTION PREVENTION	20
2.2.1. GENERAL REQUIREMENTS	20
PART 3 – PIPE CULVERTS AND STORM SEWERS	21
2.3.1. GENERAL	21



2.3.2. DESIGN	21
2.3.3. MATERIALS	22
2.3.4. PIPE LAYING	23
2.3.5. BACKFILLING	23
2.3.6. CONNECTIONS	23
PART 4 – STORMWATER SYSTEM CONSTRUCTION RECORDS	24
2.4.1. REQUIREMENTS	24
CHAPTER 3: WATER DISTRIBUTION SYSTEMS	25
PART 1 – GENERAL REQUIREMENTS	25
3.1.1. PLANS AND SPECIFICATIONS APPROVAL	25
3.1.2. SYSTEM DESIGN	25
3.1.3. MATERIALS	25
3.1.4. INSTALLATION	26
PART 2 – WATER PIPE LINES	28
3.2.1. MATERIALS	28
3.2.2. JOINTING	29
3.2.3. ENCASEMENTS	29
3.2.4. PIPE LAYING	30
3.2.5. TRACER WIRE	30
3.2.6. BACKFILLING	30
3.2.7. PRESSURE TESTING	31
3.2.8. DISINFECTION AND BACTERIOLOGICAL TESTING	32
3.2.9. SEPARATION OF WATER AND SEWER MAIN LINES	32
PART 3 – VALVES AND BOXES	33
3.3.1. MATERIALS	33
3.3.2. INSTALLATION	33
PART 4 – FIRE HYDRANTS	34
3.4.1. MATERIALS	34
3.4.2. INSTALLATION	34
PART 5 – WATER SERVICE CONNECTIONS	35
3.5.1. GENERAL	35
3.5.2. CONNECTION TO MAIN LINES	35
3.5.3. SERVICE LINES	36
3.5.4. ENCASEMENTS	36
3.5.5. SERVICE LINE TERMINALS	36

3.5.6. TRACER WIRE	36
3.5.7. FLUSHING.....	37
PART 6 – CONNECTIONS TO EXISTING MAINS	38
3.6.1. GENERAL.....	38
PART 7 – WATER SYSTEM CONSTRUCTION RECORDS.....	39
3.7.1. REQUIREMENTS.....	39
CHAPTER 4: SANITARY SEWER SYSTEMS	41
PART 1 – GENERAL REQUIREMENTS	41
4.1.1. PLANS AND SPECIFICATIONS APPROVAL.....	41
4.1.2. SYSTEM DESIGN.....	41
4.1.3. INSTALLATION	41
PART 2 – GRAVITY SEWER LINES	43
4.2.1. MATERIALS	43
4.2.2. PIPE MATERIAL TESTING.....	43
4.2.3. INSTALLATION	43
4.2.4. FLUSHING.....	47
4.2.5. VIDEO INSPECTION AND RECORDS.....	47
PART 3 – SEWER SERVICE LINES	48
4.3.1. MATERIALS	48
4.3.2. CONSTRUCTION	48
PART 4 – SEWER MANHOLES	49
4.4.1. MATERIALS	49
4.4.2. CONSTRUCTION	50
PART 5 – SEWAGE LIFT STATIONS.....	53
4.5.1. GENERAL.....	53
4.5.2. FEATURES.....	54
4.5.3. LIFT STATION SYSTEM START UP.....	54
4.5.4. ACCESS.....	55
4.5.5. SECURITY.....	55
4.5.6. STRUCTURES.....	55
PART 6 – PRESSURE SEWER LINES	55
4.6.1. MATERIALS	55
4.6.2. CONSTRUCTION	56
PART 7 – GRANULAR MATERIALS	60
4.7.1. GENERAL.....	60



4.7.2. MATERIALS	60
4.7.3. SELECT BORROW MATERIAL.....	60
PART 8 – SEWER SYSTEM CONSTRUCTION RECORDS.....	63
4.8.1. REQUIREMENTS.....	63
CHAPTER 5: STREETS	65
PART 1 – GENERAL REQUIREMENTS	65
5.1.1. BLOCKS.....	65
5.1.2. STREET LAYOUT	65
5.1.3. STREET DESIGN STANDARDS.....	66
5.1.4. SIDEWALK DESIGN STANDARDS.....	69
PART 2 – STREET CONSTRUCTION RECORDS	71
5.2.1. REQUIREMENTS.....	71
CHAPTER 6: UTILITY DEEDS AND EASEMENTS.....	72
PART 1 – GENERAL MINIMUM REQUIREMENTS.....	72
PART 2 – MONUMENTS.....	72

CHAPTER 1: LAND SUBDIVISION

PART 1 - ADMINISTRATION

1.1.1. PURPOSE AND AUTHORITY

These regulations are instated pursuant to authority granted to the Board of Aldermen by Section 17-1-23 of the Mississippi Code, 1972 Annotated. The purpose of these standards is to establish procedures governing the filing and approval of land subdivision plats and data; to establish minimum standards governing streets, utilities, and other necessary improvements; to ensure the proper coordination of future streets and their development with existing or planned streets; and to provide an ability to vary these regulations through the approval of the governing body. These Standards may be revised or amended by the Board of Aldermen in accordance with applicable laws.

1.1.2. DESIGNATION OF ADMINISTRATOR

The Mayor and/or his designee shall administer and implement the provisions of these standards and is herein referred to as the Administrator.

1.1.3. MAJOR SUBDIVISIONS

Major Subdivisions are defined as all divisions of a tract or parcel of land into four (4) or more lots, building sites, or other divisions for the immediate or future purpose of sale or building development, and all divisions of land involving the dedication of public infrastructure. The Board of Aldermen shall review and approve or deny preliminary and final plats of proposed major subdivisions. The Administrator and/or his designee will then ensure and enforce that approved subdivisions are constructed in accordance with these regulations and referenced standards.

1.1.4. MINOR SUBDIVISIONS

Minor Subdivisions are defined as all divisions of a tract or parcel of land into three (3) or less lots, building sites, or other divisions for the immediate or future purpose of sale or building development, and not involving the dedication of public infrastructure. The Mayor and/or his designee shall review and approve or deny preliminary and final plats of proposed minor subdivisions. The Administrator and/or his designee will then ensure and enforce that approved subdivisions are constructed in accordance with these regulations and referenced standards.

1.1.5. FEES

Fees may be established by the City in order to defray costs incurred through reviewing and monitoring subdivision development. These fees shall be paid as required, in accordance with the schedule as established by the City.



1.1.6. DEFINITIONS

Definitions within this document which are not specifically defined herein, or within the general definitions of the Saltillo Zoning Ordinance, or within the general definitions of the Lee County Subdivision Regulations, or within approved contract documents or specifications, shall be interpreted in accordance with the definitions considered to be normal dictionary usage.

PART 2 – PROCEDURES AND APPROVALS

1.2.1. PRE-APPLICATION CONFERENCE AND APPLICATION SUBMISSION

The developer should schedule a pre-application conference with the Administrator to discuss the preliminary plat. The purpose of this conference is to afford the developer with advice and assistance before submitting a preliminary plat for review by the City. The developer should have a preliminary plat draft and information required for preliminary plat filing prepared for the pre-application conference.

The Administrator shall review each application for completion prior to submittal for final decision. In order for an application to be considered complete, the required information listed herein must be provided, including any other pertinent information the Administrator deems necessary to render an informed decision. If the Administrator finds the application incomplete, the plat or plans shall be returned to the developer with a list of deficient items.

1.2.2. PRELIMINARY PLAT

Three (3) copies of the preliminary plat shall be provided to the Administrator, with one (1) copy being returned to the developer upon completion of the Preliminary Plat Review by the City. The Preliminary Plat shall be at a scale of not less than one (1) inch equals one hundred (100) feet and shall show on the plat or on additional documents the following proposed improvements and conditions:

- 1) Subdivision name as it would be recorded, with names and addresses of owners, with notation stating acreage, graphic scale, a north arrow, datum, benchmarks, and date of survey;
- 2) Indicate the names of adjoining property owners and subdivisions;
- 3) Vicinity map showing location of the site for the proposed subdivision with relation to other developed areas;
- 4) Bearings and distances along boundaries and mathematical closure of perimeter survey;
- 5) Location, width, and purpose of easements;
- 6) Layout and name of streets with right-of-ways and street widths;
- 7) Lot lines and size, including lot numbers;
- 8) Proposed use of all sites and lots;
- 9) Minimum building setback lines;
- 10) General contour information and conceptual grading plan (5 foot contour intervals or less);
- 11) Identification of all watercourses, marshes, flood areas, wooded areas, existing land use, and other significant features;

- 12) Proposed location, size, and general grading for all storm drainage facilities and stormwater detention/retention areas.
- 13) Proposed general location of any proposed public water, proposed hydrants, and proposed sanitary sewer lines.
- 14) Proposed general location of any proposed electric lines and facilities.
- 15) A copy of agreed "will-serve" correspondence from the City, or as otherwise approved.
- 16) Any proposed protective covenants.
- 17) Other plans or general information as is deemed necessary by the Administrator, or as required by other local ordinances, to verify compliance with the regulations of the City.
- 18) Location of proposed sidewalks along all public streets.
- 19) Designation of greenspace (and/or) open space to be preserved.
- 20) Phasing plan; provide an estimated time table for construction of the entire subdivision including:
 - a) Estimated date of submission of final construction drawings for each phase, and
 - b) Estimated date of submission of Final Plat, (as built) for each phase, and
 - c) Estimated number of Lots to be included in each phase.

1.2.3. PRELIMINARY PLAT APPROVAL

The City shall review the preliminary plat and render a decision to table, approve, deny, or approve with changes or conditions. Approval of the preliminary plat shall not constitute approval of the final plat, nor shall the preliminary plat be recorded in the Chancery Clerk's office. Approval of the preliminary plat by the City shall constitute authorization for the developer to proceed with construction plans in accordance with the changes and conditions of the approval.

Preliminary Plat reviews may take up to thirty (30) days to complete. This time may be extended or reduced by the Administrator, depending on the completeness of the application.

1.2.4. CONSTRUCTION PLANS

Construction plans specified herein shall be prepared under the supervision of a registered Professional Engineer. Three (3) sets of construction plans shall be provided to the Administrator, with one (1) set being returned to the developer upon completion of review. The construction plans shall be drawn to a scale acceptable to the Administrator and shall be prepared on sheets twenty-four (24) inches by thirty-six (36) inches in size and shall consist of the following information:

- 1) The approved Preliminary Plat and related information for the entire development;
- 2) A base survey showing all pertinent boundary and owner information for the subject property and adjoining properties;
- 3) An existing topographic map (2 foot contour intervals or less) of the entire site with detailed topographic information for on site and off site contributing drainage



- areas, including property boundaries, and delineation of all identified floodplain, floodway, wetlands, streams, bodies of water, and/or other protected areas;
- 4) Proposed site layout plan including all existing and proposed property boundaries, lot arrangements, lot numbers, rights of way, streets, utilities, easements, site vegetation, and development phasing.
 - 5) A detailed proposed grading plan, including building pad elevations for all prepared sites (2 foot contour intervals or less);
 - 6) Detailed plans on water and wastewater systems;
 - 7) A detailed Stormwater Report including: a site stormwater summary; detailed plans on culverts, drainage structures, stormwater detention/retention facilities, bridges, and other such structures; the basis for determining runoff coefficients and time of concentration; inflow hydrographs with peak flows for the 2, 10, 25, and 100 year storm frequencies; a stage/storage/discharge table for all proposed detention; details and calculation for all proposed control structures; hydrological routing of 2, 10, 25, and 100 year storm events through the proposed facilities, including an analysis of the off-site properties that may require consideration anticipating future development in addition to addressing existing conditions;
 - 8) A Storm Water Pollution and Prevention Plan, as approved by the Mississippi Department of Environmental Quality;
 - 9) Construction plans and specifications for all proposed water and wastewater systems shall be accompanied by a written letter of approval from the Mississippi State Health Department and the Mississippi Department of Environmental Quality.
 - 10) A combination plan and profile for a typical cross-section of the proposed grading, drainage, base course, and pavement;

1.2.5. CONSTRUCTION PLAN APPROVAL

The Administrator shall review, or cause to be reviewed, the construction plans for compliance with this chapter, and the referenced standards, and render an approval or disapproval. Approval of the construction plans shall not constitute approval of the final plat, nor shall the plat be recorded in the Chancery Clerk's office. Approval of the construction plans by the Administrator shall authorize the developer to proceed with the construction of infrastructure and other site improvements.

Construction plan reviews may take up to thirty (30) days to complete. This time may be extended or reduced by the Administrator, depending on the completeness of the application.

1.2.6. IMPROVEMENT SCHEDULE REQUIRED

Prior to beginning construction, the developer shall furnish to the Administrator an approximate schedule for installation of required improvements.

1.2.7. INSPECTIONS REQUIRED

The developer, or his designee, shall make periodic inspections of all improvements required by the regulations of this volume, during the course of construction and shall maintain a record of written inspection reports detailing the results of such inspections. A report of said inspections,

stamped and signed by the developer's engineer, shall be provided to the City at the time of Final Plat Approval. The Final Plat shall not be approved until such inspection report has been accepted by the City.

1.2.8. FINAL PLAT

The final plat shall conform substantially to the approved preliminary plat and, if desired by the developer, it may constitute only that portion of the approved preliminary plat that is proposed to be recorded, provided that such portion conforms to all requirements of these regulations.

Three (3) copies of the final plat shall be submitted to the Administrator, with one (1) copy being returned to the developer upon the decision of the City regarding the Final Plat. The scale of the final plat shall conform to the requirements of the County Chancery Clerk and shall contain the following information:

- 1) Primary control points, approved by the Administrator, or descriptions and "ties" to such control points to which all dimensions, angles, bearings, and similar data on the plat are referred;
- 2) Tract boundary lines, right-of-way lines of streets and easements, and property lines of lots and others sites. Sufficient data shall be shown, including accurate dimensions, bearings, deflection angles and radii, arcs, and central angles of all curves to determine readily and reproduce on the ground any line on the map;
- 3) Name and width of each street or other right-of-way;
- 4) Location, dimensions, and purpose of any easements;
- 5) Lot lines together with identification of all lots which shall be numbered consecutively;
- 6) Purpose of which sites, other than single-family residential lots, are dedicated or reserved, and any areas subject to flooding by a flood with an expected frequency of one hundred (100) year shall be clearly identified and delineated;
- 7) Minimum building setback lines on all lots and other sites;
- 8) Location and information for all areas reserved for stormwater detention/retention use;
- 9) Location and description of boundary monuments;
- 10) Title, graphic scale, north arrow, and date;
- 11) Any proposed restrictive covenants in form for recording;
- 12) Agency acceptance approval letters and related documents (i.e. Record Drawings), and construction test reports (i.e. for streets: proctors, gradations, densities, etc.) of completed construction improvements;
- 13) A metes and bounds description of the subdivision boundary;



14) Certificate of Ownership and Dedication:

This certifies that the undersigned is (are) the owner(s) of the property shown on this map, having acquired title thereto by deed(s) recorded in the Lee or Prentiss County, Mississippi Chancery Clerk's Office (whichever applies) or otherwise as shown below and that by submission of this plat or map by approval, I/We do dedicate to the City of Saltillo, Mississippi for public use all streets, easements (except drainage easements), rights-of-way and parks shown thereon for all lawful purposes to which the City may devote or allow the same to be used and upon acceptance thereof and in accordance with all city policies, ordinances, and regulations or conditions of the City of Saltillo for the benefit of the public, said dedication shall be irrevocable.

Signature of Owner(s)

15) Certificate of Accuracy:

I, _____, (Registered Professional Land Surveyor), do hereby certify that at the request of _____, the Owner(s), I have subdivided and platted the following described land as follows to wit:

(Insert Legal Description here)

I hereby certify that the plan shown and described hereon is a true and correct survey of the accuracy required by the City of Saltillo and that the monuments have been placed as shown hereon, in accordance with the requirements of the subdivision regulations.

_____, 20 ____

(SEAL)

Surveyor

MS Registration Number

16) Certificate of Acknowledgement:

Personally appeared before me, _____, the Owner(s), and _____, (Registered Professional Engineer) each of whom acknowledged to me that he signed and delivered this plat and the certificates thereon as their own act and deed, on the day and year herein mentioned.

Given under my hand and seal of office on this the ____ day of _____, 20 ____.

Notary Public

My Commission Expires: _____

17) Certificate of Approval for Recording:

I hereby certify that the subdivision plat shown hereon has been found to comply with the subdivision regulations of the City of Saltillo and has been approved by the Board of Aldermen for recording in the County Chancery Clerk's Office.

_____, 20 ____

(SEAL)

Municipal Clerk

18) Certificate of Approval and Acceptance of Dedications:

I _____ the Municipal Clerk of Saltillo, Mississippi, do certify that the City of Saltillo approved this plat or map and accepted dedication of the streets, easements, rights-of-way, and public parks shown thereon, for the best interest of the public.

_____, 20 ____

(SEAL)

Mayor

Municipal Clerk



19) Chancery Clerk's Certification:

I, _____ Chancery Clerk of the Chancery Court in and for _____ County, Mississippi, do hereby certify that the Final Plat of (name of subdivision), was filed for record in my office on this the _____ day of _____, 20 ____, and was duly recorded in Plat Cabinet _____, Slide _____ of the records of maps and plats of land of _____ County, Mississippi.

Given under my hand and seal of office on this the _____ day of _____, 20 ____.

(SEAL)

Chancery Clerk

20) Restrictive Covenants (if applicable):

The property located in (name of subdivision), as shown on this plat is subject to restrictive covenants which are set out in an instrument recorded in book _____ at page _____ of the deed of records of _____ County, Mississippi, or recorded as instrument number _____.

Chancery Clerk

1.2.9. FINAL PLAT APPROVAL

The Administrator shall recommend the final plat for City approval after examining its conformance to the approved preliminary plat, in accordance with these regulations. Approval of the Final Plat by the City shall constitute authorization for the developer to proceed with the subdivision of the approved parcels and development of said lots, including, but not limited to, applying for building permits.

1.2.10. CONDITIONS OF APPROVAL

The Final Plat shall not be approved by the City until the developer has provided a security bond in an amount equal to 125% of the total estimated cost of all public improvements remaining to be constructed at the time of Final Plat Approval. The Administrator or his designee shall be responsible for determining the bond amount, based on current construction costs and/or estimates.

At the time of dedication of the subdivision's public right-of-way to the City of Saltillo, the subdivider shall submit a title certificate and legal description of the land being dedicated. Upon approval of the final plat by the Board, an endorsement shall be made thereon by the Board and attested by the Mayor indicating approval together with the date of the approval of the Board.

1.2.11. VARIANCES

Where the City reviews and determines that the strict application of these regulations would result in substantial injustice, the City may modify or vary such requirements so that the developer may develop his property in a reasonable manner, but so that the public welfare and interest of the community are protected and the general intent and spirit of these regulations are preserved. In granting variances, the City may require such conditions that they deem necessary to maintain the general intent and spirit of the requirements.

PART 3 – ACCEPTANCE AND MAINTENANCE

1.3.1. ACCEPTANCE

The acceptance & maintenance of streets will be withheld until a final plat of that phase of the subdivision has been approved of meeting the procedures and standards set forth in these regulations and lawfully recorded in the County Chancery Clerk's office.

An official original signed copy of the recorded plat shall be returned to the Mayor for City records.

The all other infrastructure (Water & Sewer) shall be accepted one year after the date of actual commencement of use. The Contractor shall be liable until then, the City will locate the lines. If the infrastructure is not in use after one year after start of use date then retesting maybe required.



1.3.2. APPEALS

A. *Application of Appeal.* A person shall have the right to appeal an Administrator's decision to the Board. The process for requesting an appeal, as well as the standards of review, shall be described in Chapter 5, Part 2, of the Saltillo Zoning Ordinance, as amended from time to time.

B. *Limits of Authority.* An application for appeal of decisions regarding this chapter shall be based on a claim that the true intent of this ordinance or its referenced standards or the rules legally adopted thereunder have been incorrectly interpreted, the provisions of this ordinance or its referenced standards do not fully apply, or an equally good or better form of construction is proposed. The Board of Aldermen shall have no authority to waive requirements of this ordinance or its referenced codes.

1.3.3. UNLAWFUL ACTS

It shall be unlawful for any person or entity to subdivide, re-subdivide, plat, or re-plat any land into lots, blocks, or streets within the jurisdiction of the City of Saltillo, which have not been subdivided, re-subdivided, platted, or re-platted according to these regulations.

1.3.4. PENALTIES OF VIOLATIONS

Any person who develops or subdivides property, or erects, constructs, reconstructs, alters, repairs, converts, establishes, or maintains any building or structure in violation of these standards shall be guilty of a misdemeanor and shall be fined not more than one thousand dollars (\$1,000) or shall be imprisoned in jail for not more than thirty (30) days, or shall be punished by both fine and imprisonment for each offense. Each day that a violation continues shall constitute a separate and distinct violation or offense.

~END OF SECTION~

CHAPTER 2: STORMWATER MANAGEMENT

PART 1 – GENERAL REQUIREMENTS

2.1.1 PURPOSE

Proposed construction for commercial, industrial, residential, or other type developments that will result in an increase in runoff from the pre-developed or existing conditions shall be regulated as follows. New phases of existing developments that are constructed in phases and will increase runoff amounts from the pre-developed or existing conditions shall also be regulated as follows.

The intent of this section is to serve as a reference for the City staff and practicing professionals in designing storm drainage facilities within Saltillo. Criteria listed herein are the general policy of the City and may not be applicable in every situation. Each project will be evaluated on a case-by-case basis with regard to site-specific characteristics, with regard to existing storm drainage facilities, and with regard to ways that future development on and around the site could be impacted.

The developer shall be fully responsible for the design, installation, and oversight of any necessary physical improvements to connect to existing public infrastructure.

For all areas where open ditch sections are allowed (Section 5.1.2.D.), all driveway culverts shall be furnished and installed by the Sub-divider. Required sizes of driveway culverts shall be shown on the construction plans for the Subdivision.

NOTE: No environmentally sensitive area such as a stream or wetland shall be developed or approved for development without providing all applicable permits from the appropriate state and/or federal agencies.

2.1.2. METHODS

All preliminary site and subdivision plans submitted for approval shall be accompanied by a narrative describing how stormwater entering, traveling within, and leaving the site will be managed and to what extent the development will impact existing conditions on-site and off-site. All final site plan and construction drawing submittals shall be accompanied by a Stormwater Report prepared by a Professional Engineer registered in the State of Mississippi.

Methods used for computing runoff and generating hydrographs must be by one of the following methods: 1) Rational Method for drainage areas up to one hundred (100) acres or 2) Soil Conservation Service (SCS) Method (TR55) for small and medium size water sheds containing up to ten thousand (10,000) acres. Other methods may be used upon prior approval of the City Engineer.

All street and local drainage facilities shall be designed using the twenty-five (25) year storm guidelines unless more stringent requirements apply. Piped Drainage Structures shall have a



minimum size of fifteen inches (15") in diameter. Inlet and outlet headwalls and toewalls are required for all pipes. Velocities for all pipes shall be kept to a minimum and, if practical, should not exceed four (4) feet per second when flowing full; however, if outlet velocities exceed five (5) feet per second, then energy dissipation devices and vegetative channel protection must be provided.

Pipes and box culverts used for cross drains shall be designed to carry at a minimum the twenty five (25)-year storm discharge, but should also be checked against the one hundred (100)-year storm to insure that the maximum headwater depth (HW) is six inches (6") below the centerline grade of the roadway. Street catch basins may be designed for gutter spread using the ten (10)-year storm provided a four (4) minute time of concentration is used and the remainder of the system is designed for the twenty five (25)-year storm assuming each inlet captures one hundred percent (100%) of the flow (to provide additional capacity for future additions to the system and off site drainage). Inlet capacity at sags, where relief by curb overflow is not provided, shall allow for debris blockage by providing twice the computed opening for the ten (10)-year storm. Curb inlets in the roadway shall be placed in such a way that the spread of water from the ten (10)-year storm does not exceed one half of a lane width on two or three lane streets and one lane width on wider streets. When the typical section includes a full shoulder or parking lane, no encroachment onto the travel lane will be allowed.

All drainage structures that lie within streams designated as Special Flood Hazard Areas (SFHA) as defined on the National Flood Insurance Program (NFIP) maps must be designed using the one hundred (100)-year (1% chance) flood event. Designs for structures lying within these streams shall be accompanied by a no-rise certification analysis by the Professional Engineer. All no- rise certifications shall be conducted in accordance with FEMA guidelines.

The floodplain boundary information must be obtained using Federal Emergency Management Agency (FEMA) guidelines. Proposed developments located in approximate "A" zones that will be greater than fifty (50) lots or five (5) acres, whichever is lesser, must provide one hundred (100)-year base flood elevation data. This data should be obtained using appropriate methodologies accepted by FEMA.

2.1.3. STORMWATER RETENTION AND DETENTION

Whenever the Stormwater Report indicates that an adverse stormwater runoff related impact is expected to result from the development of a property, that project shall be required to provide a stormwater detention facility or facilities so that peak flows from the developed site do not exceed those associated with the pre developed site. The detention facility shall be designed to accommodate a twenty five (25)-year post development event with the discharge structure designed to release the ten (10)-year pre-development flow. Larger projects, in excess of fifteen (15) acres, may be designed to release the twenty five (25)-year pre-development flow.

Detention and retention ponds shall be designed with adequate freeboard to protect against overtopping of the dam or levee from the one hundred (100)-year storm. A variety of methods of achieving stormwater management goals are acceptable in providing detention facilities. The type of facility provided shall be based on the following criteria:

1. The type of development for which the detention facility is intended to protect.
2. Volume of stormwater to be stored.
3. Origin and magnitude of the flows to be managed.
4. Topographic opportunities and limitations.
5. Safety considerations.
6. Maintenance requirements.
7. Aesthetic considerations.
8. Likelihood of facility operation interfering with access to public or private facilities.
9. Proximity of facility to property lines, utilities, buffers, etc.
10. Similar site-specific constraints as necessary.

In addition to standard stormwater facilities, credit may be given to developers for preserving mature trees to be used in a detention or stormwater quality facility on a development site. Mature native trees are an integral part of the stormwater treatment process and should be preserved and maintained where applicable. Stormwater storage credits will be given in the amount of one half (1/2) cubic foot per inch (caliper inch at breast height) of mature trees preserved on site. For example, if ten (10) mature trees with a diameter of twelve (12) inches were preserved in an open, pervious area of the site (or other greenspace that is not in parking lots), the developer would receive credit for sixty (60) cubic feet of storage saved. Credits would be given at the discretion of the City Engineer based on location, size and type of trees. It shall be the responsibility of the developer to provide adequate information concerning the location, size, quality, and type of all trees to be preserved. Such information can be provided by means of a survey or other similar and pertinent documentation.

The use of detention structures, which are greater than four feet (4') in depth, is strongly discouraged. When a detention structure is over four feet (4') deep and in a location that constitutes a danger to human habitation, a permanent fence or barrier and warning signs shall protect it. These types of structures should be avoided if at all possible. Fences shall be a minimum of five feet (5') in height with a ten foot (10') wide gate. All fencing must be decorative wood or dark coated metal, such as aluminum picket or powder coated chain-link, and must be specifically approved, along with a plan of access and appropriate easements, by the City during the plans review process. Detention areas are to be owned and maintained by the Home Owner's Association and protected by subdivision covenants.

Fences shall be located on the outside edge of the twenty foot (20') perimeter easement. An opaque fence or evergreen landscape buffer must be provided around such detention structures. Drainage easements suitable for the construction and maintenance of the drainage system shall be provided. A minimum of twenty feet (20') in width will be required for any drainage easement along a drainage pipe, ditch, stream or other area that is designated for stormwater to flow. No obstruction shall be built; constructed or planted that would inhibit proper function of the drainage system. All detention facilities shall be accessible from a public street by a minimum twenty foot (20') access easement, and there shall be an easement for the detention facility including twenty feet (20') beyond the toe of the side slope of the containment berm of the structure. No fences or planting of shrubbery shall be allowed on access easements.

Fences and/or shrubbery may be placed within a piped drainage easement, if an indemnification agreement is provided to the City.

Drainage channels and detention/retention facilities should have maintained banks with slopes no steeper than three linear feet (3') per one vertical foot (3:1). Channel protection should be provided in vegetative form unless otherwise unsuitable. Where vegetative protection is proposed, the use of temporary or permanent erosion control material is required. At a minimum, the use of excelsior mats, or on approved equal, with sod or seed is required.

PART 2 – STORMWATER POLLUTION PREVENTION

2.2.1. GENERAL REQUIREMENTS

Prior to beginning development work, sediment control measures shall be established by the developer to prevent stormwater pollution. Structural practices shall be implemented to divert flows from exposed soils, temporarily store flows, or otherwise control runoff in order to prevent pollutants from leaving development project sites and rights-of-way.

The City will not issue approval for work to begin on a project without the proper permits on file. It shall be the responsibility of the developer to apply for, obtain, and maintain applicable stormwater permits from the Mississippi Department of Environmental Quality. Permits shall remain on site at all times for inspection by City and/or MDEQ personnel.

Before beginning projects that will encompass a disturbed area greater than five (5) acres, the developer/builder shall submit a Stormwater Pollution Prevention Plan (SWPPP) to the Mississippi Department of Environmental Quality (MDEQ) for a Large Construction Stormwater General Permit. A copy of the approved SWPPP plan must be provided to the City with construction plans.

Projects that will have a total disturbed area of less than five (5) acres, but greater than one (1) acre shall be covered under a Small Construction Stormwater General Permit.

Projects that disturb an area of less than one (1) acre that may not be required to obtain stormwater pollution prevention permits shall follow best management practices regarding erosion and sediment control.

As a minimum, the developer / contractor shall provide straw bales or silt fences as a temporary structural practice to minimize erosion and sediment runoff. Straw bales and silt fences shall be properly placed to effectively retain sediment in each independent runoff area; then, as work progresses, shall be removed/replaced/relocated as needed. Erosion control measures must remain in place until vegetative establishment has occurred across the newly developed drainage area.

PART 3 – PIPE CULVERTS AND STORM SEWERS

2.3.1. GENERAL

The minimum diameter for pipe culverts and storm drain pipe shall be ten inches (10”), and when used as a culvert, the length shall be such that the ends project at least four feet (4’) beyond the edge of the pavements or beyond the back of the curb. The pipe shall be sized to not impede the flow of the ditch.

2.3.2. DESIGN

The design of stormwater drainage systems shall insure adequate control of stormwater runoff through the use of properly sized and positioned drainage structures including but not limited to curb and gutter, curb and grate inlets, raised grates, stormwater sewer pipe, box culverts, intersectional drains, open ditches, and bridges. Some such structures may also be required at side and rear lot lines.

The design of all stormwater drainage systems (including main channels) shall be in accordance with the City’s plan (if any) for the basin in which the development is located and shall provide for potential affects to upstream and downstream developments in the basin. Drainage facilities shall be designed to meet all City ordinances and prevent excessive runoff onto adjacent properties. Cross drains shall be provided to accommodate all natural water flow and shall be of sufficient length to permit construction of a full width roadway including side slopes. Headwalls or flared end sections, aprons, channel bottom, and slope protection shall be provided at the upstream and discharge end of the cross drains as required by the Public Works Director or City Engineer. The use of excelsior mats or an approved equal will provide adequate protection.

The following stormwater design frequencies shall be used in computing design distribution:

- 100-Year: All major streams, channels, bridges, open ditches, or drains within the jurisdictional limits of the City of Saltillo.
- 50-Year: Minor streams, channels, open ditches, or sub-drains from tributary to main streams.
- 25-Year: Side drains and miscellaneous culverts where flooding would cause minor adverse affects.

No individual, partnership or corporation shall deepen, widen, fill, reroute or change the location of any existing ditch, stream, or drainage structure without first submitting plans and obtaining written permission from the U. S. Army Corps of Engineers, Public Works Director, or City Engineer.

The following design criteria shall apply to all storm drainage pipe and culverts:

- A. Calculation of design flows for drainage areas less than ten (10) acres: All pipes, side drains, and open ditches shall be designed using the accepted methodologies. The minimum storm drainage pipe size shall be fifteen inches (15”) and shall be obtained using the Rational Formula.



- B. Storm sewer design velocities shall not exceed ten feet (10') per second. For small, compact drainage basins less than ten (10) acres, the peak runoff shall be computed from the Rational Formula.
- C. Calculation of design flows from drainage areas greater than ten (10) acres: Design flows shall be obtained by using accepted methodologies suitable for urbanized streams.
- D. All pipes, side drains and open ditches shall be designed using the applicable frequency curve. Storm sewer design velocities shall not exceed ten feet (10') per second.

The following requirements shall apply to the construction of streets, curb and gutter, and inlets.

- A. The horizontal and vertical alignment of streets shall be compatible with the stormwater runoff system and drainage design.
- B. Street Grades shall be coordinated with lot drainage as proposed in the grading plan. Street grades shall be above the one hundred (100)-year frequency flood level.
- C. The hydraulic capacity of curb inlets shall be determined by generally accepted engineering procedures taking into consideration roughness and street cross slope. The design depth of flow in the curb and gutter section shall not exceed four inches (4").
- D. The hydraulic capacity of curb inlets shall be determined by generally accepted engineering procedures taking into consideration inlet geometry and characteristics of the gutter flow. Curb inlets shall be spaced to limit the spread of water to not more than one quarter (1/4) of the street width during a design storm of ten (10) year return period and fifteen (15) minute duration. Inlets shall also be placed at all low points in the gutter grade, at intersections where necessary to prevent gutter flow from crossing traffic lanes of an intersecting street or at points of special concern designated by the Public Works Director or City Engineer.
- E. Finished grades of all buildings shall be a minimum of one foot (1') above the one hundred (100)-year flood elevation.
- F. The structural design of all box culverts or bridges shall conform to the standard plan of the Mississippi State Highway Department for a load capacity of HS-20 minimum.
- G. All culverts, cross drainage, and storm sewers shall be constructed in accordance with the technical specifications contained herein.

2.3.3. MATERIALS

All materials and construction practices shall conform to the requirements of the Mississippi Standard Specifications for State Aid Road and Bridge Construction (2004 Edition).

Head walls or flared end sections shall be provided on all eighteen inch (18") pipes and larger.

Plastic Pipe and fittings shall conform to the requirements of Type "S" High Density Polyethylene (HDPE) corrugated pipe under AASHTO M 294. It shall be "N-12 Pipe", as manufactured by Advance Drainage Systems, Hilliard, Ohio, or equal. Couplings used at pipe joints shall provide a watertight connection and gaskets shall conform to the requirements under ASTM F-477.

Reinforced concrete pipe shall conform to ASTM C-76.

2.3.4. PIPE LAYING

Pipe shall be installed according to the Manufacturer's recommendations. Excavation shall be true to line and grade within 0.05 feet. Excavation carried below the grade shall be backfilled at the Contractor's expense with selected materials. Unsuitable materials excavated from the trenches shall not be used for backfill and shall be disposed of as directed by the Engineer. Any material encountered in way of pipe trenches, including buried drainage structures and obstructions, shall be excavated.

The trench width shall not be less than twelve inches (12") greater than the outside diameter of the pipe. The Contractor shall do such trench bracing, de-watering, sheathing, or shoring necessary to perform and protect the excavation, and shall remove such material as backfill progresses.

The pipe shall be firmly and accurately set to line and grade so that the invert will be smooth and uniform, and any pipe which is not in true alignment, or which shows any settlement after laying, shall be taken up and re-laid. Pipe shall be laid on a prepared bed which will provide a full bearing for the barrel and which is uniformly firm throughout its entire length.

Concrete pipe shall be used beneath all paved areas.

All joints shall be wrapped with approved materials.

2.3.5. BACKFILLING

The backfill material shall be approved by the City Engineer. Great care shall be used to obtain thorough compaction under the haunches and along the sides to the top of the pipe. The backfill shall be placed in loose layers not exceeding six inches (6") in depth and successive layers shall not be placed until thorough compaction is obtained. Trenches under areas to be paved shall be compacted to ninety-five percent (95%) Standard Proctor density.

2.3.6. CONNECTIONS

Where the plans call for connections to existing or proposed structures or lines, these connections shall be watertight and made so that a smooth uniform flow line will be obtained.

The joints of all pipe culverts to other drainage structures shall be caulked and filled with mortar. Joints shall be thoroughly wet before applying mortar, and sufficient mortar shall be used to form a bead around the outside of the joint and to fill the whole joint to the inside of the connection. The inside of the joint shall be wiped and finished smooth. After the initial set, the mortar on the outside shall be cured with a cover of thoroughly wetted earth or burlap.



PART 4 – STORMWATER SYSTEM CONSTRUCTION RECORDS

2.4.1. REQUIREMENTS

The following records must be provided prior to approval of the Final Plat or release of the Construction Bond:

- A. A certification letter from the developer's engineer that the improvements were constructed in substantial conformance with the approved construction plans and specifications, accompanied by inspection documentation records and construction inspection photographs. The developer, or his designee, is responsible for maintaining inspection records to ensure that all improvements were constructed according to approved plans.
- B. RECORD DRAWINGS shall accurately represent the completed construction including locations of service stub outs and appurtenances.
- C. RECORD DRAWINGS of the completed construction shall be provided in both hard copy and electronic formats. Provide four (4) printed sets and two (2) sets on CD or other media in PDF or other acceptable machine-readable file format.
- D. Copies of the manufacturer's literature necessary for reference in operating and maintaining the facilities including but not limited to manufacturer's product descriptive literature for materials incorporated into the work, operation and maintenance manuals for equipment, copies basic warranty information, etc.
- E. Contact information for the source of supply.
- F. Other information as may be requested by the Administrator.

~END OF SECTION~

CHAPTER 3: WATER DISTRIBUTION SYSTEMS

PART 1 – GENERAL REQUIREMENTS

The water distribution system shall meet the requirements of the BUREAU OF ENVIRONMENTAL HEALTH, MISSISSIPPI STATE DEPARTMENT OF HEALTH, DIVISION OF WATER SUPPLY and conform to the CITY OF SALTILLO STANDARDS.

The developer shall be fully responsible for the design, installation, and oversight of any necessary physical improvements to connect to existing public infrastructure.

3.1.1. PLANS AND SPECIFICATIONS APPROVAL

The Mississippi State Department of Health requires:

“Prior to advertising for bids, or prior to beginning construction where bids are not received on a new public water system, or for extensions or modifications to an existing public water system, plans and specifications shall be approved in writing by the Division of Water Supply”.

“Plans and specifications must be prepared, sealed, and signed by professional engineer registered to practice in Mississippi in accordance with the requirements of the Mississippi State Board of Registration for Professional Engineers and Land Surveyors.”

3.1.2. SYSTEM DESIGN

Unless otherwise recommended by the City Engineer, the distribution system shall be so designed as to maintain a minimum dynamic pressure of forty (40) psi. Maximum static pressure should not exceed eighty (80) psi.

Water mains should be designed based on hydraulic analysis using an appropriate friction coefficient, but shall not be less than six inches (6”). The maximum Hazen-Williams C value to be used is one hundred twenty (120).

The minimum main size supplying fire hydrants with pumper connections shall be as determined by hydraulic analysis using anticipated fire flows.

3.1.3. MATERIALS

All materials not specifically referenced herein shall be non-toxic and approved for use in potable water systems by American Water Works Association (AWWA), U.S. Environmental Protection Agency (EPA), Underwriters Laboratory (UL), National Sanitation Foundation (NSF), or other appropriate organization.

Ductile iron pipe and fittings shall comply with the latest application standards issued by the AWWA.

PVC pipe shall bear the NSF seal for potable water and meet the requirements of ASTM D 1748 for Class 12454 compounds. The pipe shall meet the latest revisions of the applicable AWWA



Standards.

3.1.4. INSTALLATION

Pipe installation shall comply with generally accepted standards of good workmanship, including applicable AWWA and industry standards, along with, but not limited to the following:

- A. A continuous uniform bedding shall be provided, free of injurious stones or debris within six inches (6") of the pipe in the bedding and cover material.
- B. There shall be a minimum of thirty-six inches (36") of cover.
- C. Except for street and driveway crossings, water lines shall be located outside of paved areas. Exceptions will be considered on a case-by-case basis. Water lines shall be installed a minimum of five feet (5') behind the back of the curb.
- D. While under construction, unattended exposed pipelines must have the ends capped.
- E. Adequate separation from other utilities for maintenance and/or repair should be provided.
- F. Water mains shall be laid at least ten feet (10') horizontally from any sanitary sewer or manhole. Where local conditions prevent ten feet (10') horizontal separation, the City may allow the water line to be laid closer to the sewer line if the following requirements are met:
 - a. The developer must obtain written approval from the Mississippi State Health Department.
 - b. If local conditions prevent ten feet (10') horizontal separation, the water main may be laid closer to the sewer line provided they are in a separate trench and the bottom of the water line is eighteen inches (18") above the top of the sewer lines.
 - c. Where this ten foot (10') horizontal separation cannot be maintained, the water line should be ductile iron with water line joints located at the maximum distance possible from sewer line joints. PVC pipe may be used if it is protected by a steel casing.
 - d. Where water lines cross sewer lines, the pipe segments should be centered to provide maximum spacing of joints of both water and sewer lines. A vertical separation of at least eighteen inches (18") should be maintained (water over sewer).

- G. Water lines crossing ditches where less than thirty-six inches (36") of cover is maintained or crossing streams should be ductile iron pipe, or protected by a steel casing. Adequate support and anchorage should be provided on both sides of the ditch.
- H. Pipe lines including main and service lines that cross roadways shall be protected by a casing meeting the requirements of the agency involved. Casings for service lines under collector and local streets installed by open cut may be PVC pipe or steel pipe. Encasements for all main lines shall be steel.
- I. Pipe lines crossing railroads shall be protected by a steel casing. A copy of the railroad permit for the crossing shall be furnished to the City.
- J. All water users shall be supplied individually from a service line extended directly from the main line.
- K. A sufficient number of valves shall be provided to limit the number of meters isolated during line maintenance and repairs. Valves shall be located and lines looped so that not more than twenty-five (25) meters will be isolated at a time. Valve location spacing shall not exceed one thousand feet (1,000') along any segment. Valves shall be provided at each fire hydrant.
- L. Pressure and leakage tests should be completed and conform to the current AWWA Standard, C 600 Section 5. Provide records of test results indicating witness.
- M. There shall be no physical connection (cross connections) between the distribution system and any pipes, pumps, hydrants, or tanks whereby unsafe water or any contaminants may be caused to enter the water system. An appropriate backflow prevention device shall be installed on each service extension where an existing or potential health hazard exists or where a hazardous hydraulic condition may be allowed to exist. Where backflow prevention devices are required, they must be installed inside of an associated building, or equipped with a prefabricated exterior housing to be approved by the City Engineer. These devices should be located in a serviceable area but screened away from the public view. Prior to service being connected to a public water system, all wells or water sources owned or used previously by the potential customer shall be physically disconnected from the plumbing to be supplied by the public water system.
- O. All dead end mains shall terminate with one of the following:
 - a. If a 4-inch or larger water line terminates, a standard fire hydrant shall be required at the end of the line. However, a two inch (2") flushing hydrant may be installed if the line serving it is 3 inches in diameter or less. A main line valve shall be placed on a tee of the the hydrant in order to extend the line in the future, this does not include the hydrant valve.



- b. A fire hydrant may be installed. Hydrant type and installation shall be per the specifications herein, at the discretion of the public works director.

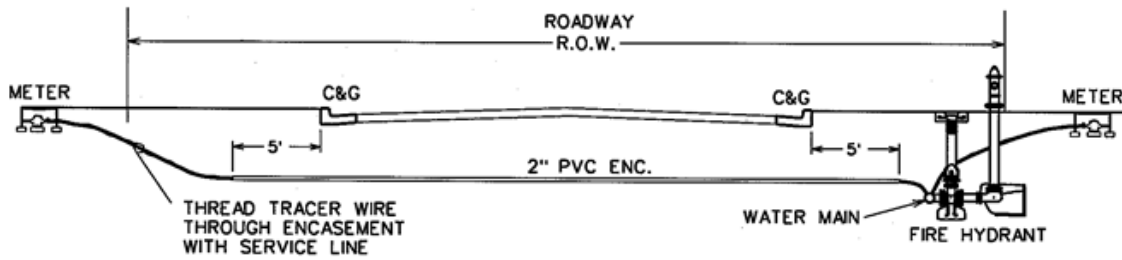

ILLUSTRATION 3.1.4 – WATER SYSTEM TYPICAL DETAILS

PART 2 – WATER PIPE LINES

3.2.1. MATERIALS

Except as otherwise provided, water mains shall be six inch (6") minimum, PVC, or ductile iron pipe. Ductile Iron Pipe for water pipe lines where required shall be in accordance with ANSI/A21.50 and ANSI/A 21.51 mechanical or push-on jointed and shall be cement lined in accordance with ANSI/A 21.4. Rubber gasket joints shall be in accordance with ANSI 21.11. The pressure classes for ductile iron pipe shall be: PC 350 for eight to twelve inch (8"-12") pipe.

Flanged joint pipe shall be in accordance with ANSI/A21.10 and ANSI/A21.15. Bolts used on underground flanges shall be a corrosion resistant type such as Corten, U.S. Alloy, silicon bronze, or others with prior approval of the City.

Restrained Joint Pipe shall be rated for 250-PSI minimum. The joints, gaskets, and accessories for restrained joints shall meet applicable requirements of ANSI/A21.11. Retainer glands for mechanical joint pipe shall be Megalug by Ebaa Iron, Uni-Flange Series 1400 restrained joint device or approved equal.

Plastic Pipe shall be rigid polyvinyl chloride pipe in accordance with ASTM Specification D-1784, cell classification 12454. Additives and fillers including, but not limited to, stabilizers, antioxidants, lubricants, and colorants shall not exceed 10 parts by weight per 100 of PVC resin in the compound. Pipe shall be Class 200 (SDR 21) per ASTM D-2241 with integral bell for gasketed slip joints or AWWA C-900 Class 150 (DR18) with integral bell for gasketed slip joints. "O"-ring joints will not be accepted. Gasket joints shall be in accordance with ASTM D-3139. All plastic pipe shall be installed within one (1) year of the date of manufacture indicated on the pipe.

- A. Pipe Fittings: Fittings for ductile iron and PVC pipe shall be ductile iron mechanical joint fittings, ANSI Specification A21.53, A21.11 as applicable. Fittings shall be rated for a working water pressure of 350 psi. Ductile iron fittings shall be uniformly coated on the inside with cement-mortar lining conforming to ANSI

Specifications A21.4. Mechanical joint fittings with Ebaa Iron Megalug glands and gaskets or Uni-Flange Series 1400 restrained joint device may be used where restrained joint fittings are specified. Pipe Fittings for Flanged Connections shall be ANSI Specifications A21.10, Class 125, ductile iron fittings.

- B. Thrust Blocks: Concrete thrust blocks, or similar method approved by the Administrator, shall be installed around fittings at the locations and of the volume and strength required to withstand thrust reactions at the test pressure. Where directional changes occur in a vertical plane, approved mechanical retainers shall be used. See Diagram.

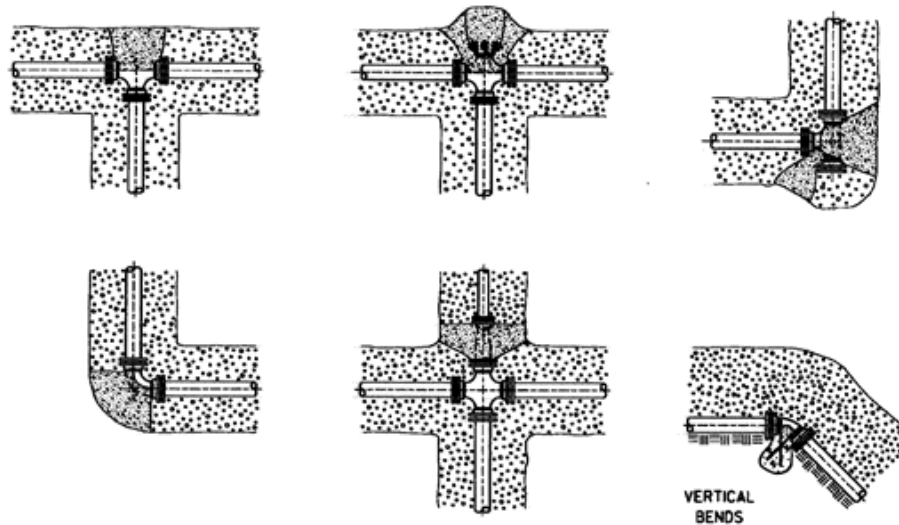

ILLUSTRATION 3.2.1. – THRUST BLOCKING

NOTE: DUE TO VARIABLE SOIL CONDITIONS, THRUST BLOCKING METHODS MUST BE APPROVED BY THE CITY ENGINEER OR PUBLIC WORKS DEPARTMENT PRIOR TO INSTALLATION.

3.2.2. JOINTING

Ductile Iron Pipe - In general, all joints shall be in accordance with the manufacturer's instructions exercising extreme care to clean all parts before assembly. Joints shall be made under dry conditions. Underground flanges shall be wrapped with 8 mil black polyethylene material conforming to ANSI A21.5 and taped in place before backfilling.

Plastic Pipe - Joints in plastic pipe shall be rubber gasket push-on type. Push-on joints shall be made in accordance with the manufacturer's instructions. The resulting joints shall be clean and watertight.

3.2.3. ENCASEMENTS

Encasement for water lines at roadway crossings shall be new black steel pipe per ASTM A252, Grade 2, ASTM A53, Grade B or better. Minimum wall thickness shall be 0.188" for sizes 12" and less and 0.250" for 14" and above or as required by the agency involved. Joints shall be welded. Trenching and backfilling shall be performed in conformity with the Water Pipe Lines



standard.

3.2.4. PIPE LAYING

The pipe shall be lowered into the trench in such a manner as to prevent damage to the pipe or pipe coating. It shall not be dropped or dumped during unloading or laying. Foreign matter and dirt shall be prevented from entering the pipe. A minimum cover of thirty-six inches (36"), measured from the top of the pipe shall be provided. Plastic pipes not encased and under vehicular traffic areas shall be covered at least forty-eight inches (48").

3.2.5. TRACER WIRE

Twelve gauge (minimum) insulated single-strand solid copper tracer wire shall be installed with all plastic mains and service lines to facilitate location with a pipe locator. The tracer wire shall be laid in the trench with the plastic pipe.

The tracer wire shall be brought up and terminated in a tracer wire test station at each valve and at intervals along pipelines not to exceed five hundred feet (500'). Tracer wire test stations shall be Rhino TriView Flex with internal test station as manufactured by REPNET, Inc. or equal. The tracer wire station shall be installed by sliding it over a six foot (6') long 1-1/2 lb. per foot U-channel post driven eighteen to twenty four inches (18" - 24") into the ground and securing it with a bolt or rivet as recommended by the manufacturer. Where utilities are located in the front or side yard, use "snakepit" style tracing wire system with six inch (6") top flange in-grade locator markers. Identification decals shall be affixed to all three sides of the post.

3.2.6. BACKFILLING

Trenching and excavation shall be backfilled immediately after the pipes are laid. The initial backfill shall extend to twelve inch (12") above the pipe. The initial backfill shall be thoroughly and carefully tamped before the next layer is placed. The remainder of the backfill shall be as follows:

In areas not to be paved, the backfill may be fine, loose soil, free from large clods, stones, frozen earth, debris or any material with an exceptionally high void content. The backfill may be accomplished by dozing in layers of approximately one foot each. A windrow shall be left over the trench and bladed and shifted as necessary as settling occurs. For graveled areas, after maximum settlement has been reached, excess material shall be hauled away and washed gravel or crushed stone added as necessary.

In areas to be paved, the trench soils shall be tested by the design engineer to determine their suitability for use as backfill material. If the trench soils are found to be unsuitable, they shall be replaced with suitable materials. Backfill in areas to be paved shall be placed in twelve inch (12") lifts and each lift compacted to ninety five percent (95%) Standard Proctor density. Backfill shall extend to the top of the subgrade.

The location of backfill density tests shall be at the discretion of the design engineer. Generally, one sample will be taken mid-trench depth and one on top of the material each two hundred feet (200')+ along the trench. In the event of failed density tests, the compaction shall be continued and water added until the optimum moisture content is reached and the samples

meet or exceed the specified minimum density.

3.2.7. PRESSURE TESTING

After the pipe has been laid, all newly laid pipe and selected valved sections shall be subjected to a hydrostatic pressure equal to one and one-half (1-1/2) times the normal static water pressure, but not less than 100 psi. All pressure tests must be conducted in the supervision of the City Engineer or City Building Inspector.

Test Pressures shall:

- A. Not exceed pipe or thrust-restrain design pressures (Backfill pipe trenches sufficiently and provide reaction blocking hydrostatic testing.)
- B. Be of at least 2-hour duration.
- C. Not vary by more than + 5 psi for the duration of the test.
- D. Not exceed the rated pressure of the valves when the pressure boundary of the test section includes closed, resilient-seated gate valves or butterfly valves.

Each valved section of pipe shall be slowly filled with water. The specified test pressure shall be applied, by means of a pump connected to the pipe in a satisfactory manner. Valves shall not be operated in either the opening or closing direction at differential pressures above the rated pressure. The system shall be allowed to stabilize at the test pressure before the leakage test is conducted.

Before applying the specified test pressure, air shall be expelled completely from the section of pipe under test. If permanent air vents are not located at all high points, corporation stops shall be installed at such points so that the air can be expelled as the line is filled with water. After all the air has been expelled, the corporation stops shall be closed and the test pressure applied. At the conclusion of the pressure test, the corporation stops shall be left in place and record of their location provided.

Damaged or defective pipe, fittings, valves, or hydrants that are discovered following the pressure test shall be repaired or replaced and the test shall be repeated until satisfactory results are obtained.

A leakage test shall be conducted concurrently with the pressure test. Leakage shall be defined as the quantity of water that must be supplied into a pipe to maintain pressure within five (5) psi of the specified test pressure after the pipe has been filled with water and the air has been expelled. Leakage shall not be measured by a drop in pressure in a test section over a period of time.

No pipe installation will be accepted if the leakage is greater than the allowable leakage at various pressures as shown in the table below.



TABLE 3.2.7. ALLOWABLE LEAKAGE PER 1000 FT OF PIPELINE*-----GPH

Avg. Test Pressure	<u>Nominal Pipe Diameter (inches)</u>									
	3	4	6	8	10	12	14	16	18	24
180	0.31	0.41	0.61	0.81	1.01	1.21	1.41	1.61	1.82	2.42
175	0.30	0.40	0.59	0.80	0.99	1.19	1.39	1.59	1.79	2.38
150	0.28	0.37	0.55	0.74	0.92	1.10	1.29	1.47	1.66	2.21
125	0.25	0.34	0.50	0.67	0.84	1.01	1.18	1.34	1.51	2.01
100	0.23	0.30	0.45	0.60	0.75	0.90	1.05	1.20	1.35	1.80

Note: If the pipeline under test contains sections of various diameters, the allowable leakage will be the sum of the computed leakage for each size.

When testing against closed metal-seated valves, an additional leakage per closed valve of 0.0078 gal/h/in. of nominal valve size shall be allowed. Acceptance shall be determined on the basis of allowable leakage. If any test of installed pipe discloses leakage greater than that specified, repairs shall be made as necessary until the leakage is within the specified allowance.

All visible leaks are to be repaired regardless of the amount of leakage. Tests must be observed by appropriate City Officials and certification of such observance must appear on the test record.

3.2.8. DISINFECTION AND BACTERIOLOGICAL TESTING

After the pipe has been laid, all newly laid pipe and selected valved sections shall be subjected to a hydrostatic pressure equal to one and one-half (1-1/2) times the normal static water pressure, but not less than 100 psi. All pressure tests must be conducted in the supervision of the City Engineer or City Building Inspector.

Disinfection shall be in valved sections and may be done concurrently with pressure testing. Flushing and disinfection shall be in accordance with AWWA Specification C651. After completion of the disinfection, arrangements shall be made to collect a least one sample from every dead-end line and every major looped line for bacteriological examination. The sample shall be collected by a representative of the Mississippi State Department of Health or the registered professional Engineer in charge of the project or the certified operator of the public water supply. Water being collected for testing shall not have a chlorine residual higher than is normally maintained in other part of the distribution system.

NO COLIFORM BACTERIA AND NO CONFLUENT GROWTH INDICATION SHALL CONSTITUTE A SATISFACTORY SAMPLE WHEN ANALYZED BY THE MISSISSIPPI STATE DEPARTMENT OF HEALTH OR A LABORATORY CERTIFIED BY THE STATE. A COPY OF THE TEST RESULTS SHALL BE FURNISHED TO THE CITY.

3.2.9. SEPARATION OF WATER AND SEWER MAIN LINES

Water mains shall be laid at least ten feet (10') horizontally from any parallel sanitary sewer or storm sewer; the distance shall be measured edge-to-edge. When local conditions prevent a

horizontal separation of 10 feet (10'), the water main shall be ductile iron pipe and shall be laid at least 18 inches (18") above the top of the sewer. Water mains crossing sanitary sewers shall be laid to provide a separation of at least 18 inches (18") between the bottom of the water main and the top of the sewer. No water pipe shall pass through or come into contact with any part of a sewer manhole. In places where the water line passes underneath a sanitary sewer line, the water line shall be installed so the midpoint of a full pipe length of water line is centered on the sanitary sewer.

Deviations must be approved by the Mississippi State Department of Health on a case-by-case basis.

PART 3 – VALVES AND BOXES

3.3.1. MATERIALS

Gate valves shall be resilient seated gate valves conforming to AWWA Standard C509, iron body, bronze mounted, non-rising stem with O-ring seals, opening counterclockwise, M&H Valve Company. All cast iron parts, inside and out except contact or bearing surfaces of resilient seated valves, shall be coated with an approved surface tolerant hi-solids catalyzed epoxy coating. Valves sixteen inches (16") and larger shall be equipped with a totally enclosed bevel gear operator, indicators, rollers, and tracks with AWWA sized bypasses. Buried valves shall have an AWWA wrench nut, and rubber ring push-on joint ends for PVC pipe; mechanical joint ends for ductile iron pipe, but may have flanged ends (ANSI B16.1) - (125 lb.) where necessary.

Valve boxes for underground installation of valves shall be fine grain gray iron castings, 5-1/4 inch shaft, screw type, adjustable height, round base, Vulcan V8460, Fastech or equal per ASTM Specification A48 Class 30B. Shaft extension pieces shall be installed where necessary. Valve boxes shall have the word "WATER" cast into the top of the cover. Valve boxes shall not be painted.

3.3.2. INSTALLATION

Valves and boxes shall be installed truly vertical. Joints and leakage shall be as specified under the Water Pipe Lines standard. The valve box shall not transmit shock or stress to the valve and shall be centered and plumb over the wrench nut of the valve. In unpaved areas, an 18"x18"x6" reinforced, formed concrete pad shall be provided at the finished grade around the top of the box. The top of the valve box should be flush with grade.

Tracer wire shall be terminated in a test station only and not in the valve box.



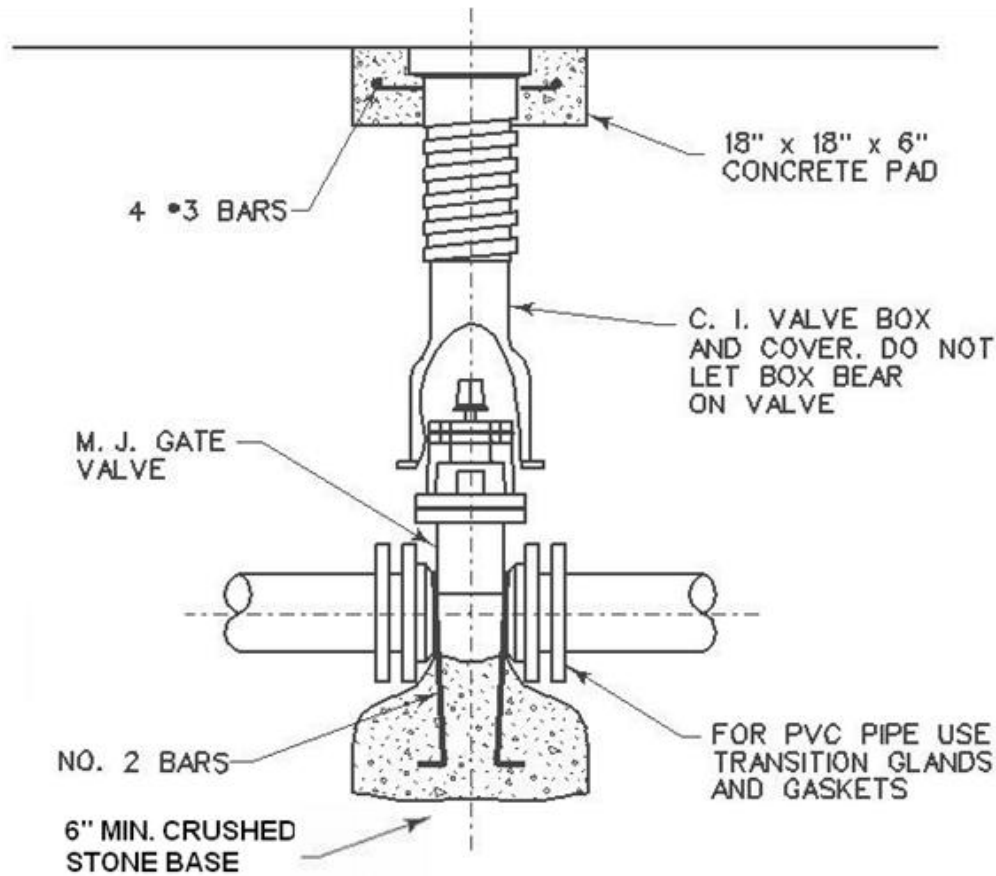

ILLUSTRATION 3.3.2. – TYPICAL VALVE INSTALLATION

PART 4 – FIRE HYDRANTS

3.4.1. MATERIALS

Fire hydrants shall conform to AWWA Standard C-502. Hydrants shall be Mueller “Super Centurian – 250” or M & H “Style 129” or equal for a minimum of 200 psi working pressure. Hydrants shall be of the 5-1/4” valve size for connections to mains with 6” mechanical joint connections, with 42” minimum cover and shall be fitted with 2-1/2” hose connections and one 4-1/2” steamer connection with National Standard threads. Stems shall be provided with “O”-ring seals. The above ground part of the hydrant shall be given a prime coat then two coats of an approved, weather-proof paint. Hydrants shall be of the traffic model type. The riser shall be designed so that if breakage occurs, the breakage flange, ring, or bolts and the stem will break before damage is done to the riser and the hydrant can be restored to service by replacing the breakage parts.

3.4.2. INSTALLATION

Hydrants shall be set perpendicular and the base braced against the water pressure at the shoe with concrete blocking, or similar method approved by the Administrator. Three cubic feet of washed gravel shall be placed around the drain port to provide the water absorption to prevent freezing. Concrete blocking shall not interfere with hydrant drainage.

In residential developments, a hydrant is required per five (5) houses built. For every house built over a multiple of five, an additional hydrant is required. Hydrants shall be spaced at not more than 500 feet (500') in residential developments and at not more than 300 feet (300') in commercial developments. Hydrants shall be installed with the hose connections in the proper direction for attachment to the fire hose. A clear space shall be provided around all fire hydrants defined by a circle with a minimum radius of 4 feet (4').

The collision ring of hydrants shall be set flush with (not below) the finished grade surface or not more than six inches (6") above the finished surface. Barrel extension sections shall be installed where necessary.

A valve shall be provided to isolate each hydrant from the main line. The valve shall be furnished and installed in accordance with the VALVES AND BOXES section and if possible use anchorcouplings from valve to hydrant and use anchor tee's.

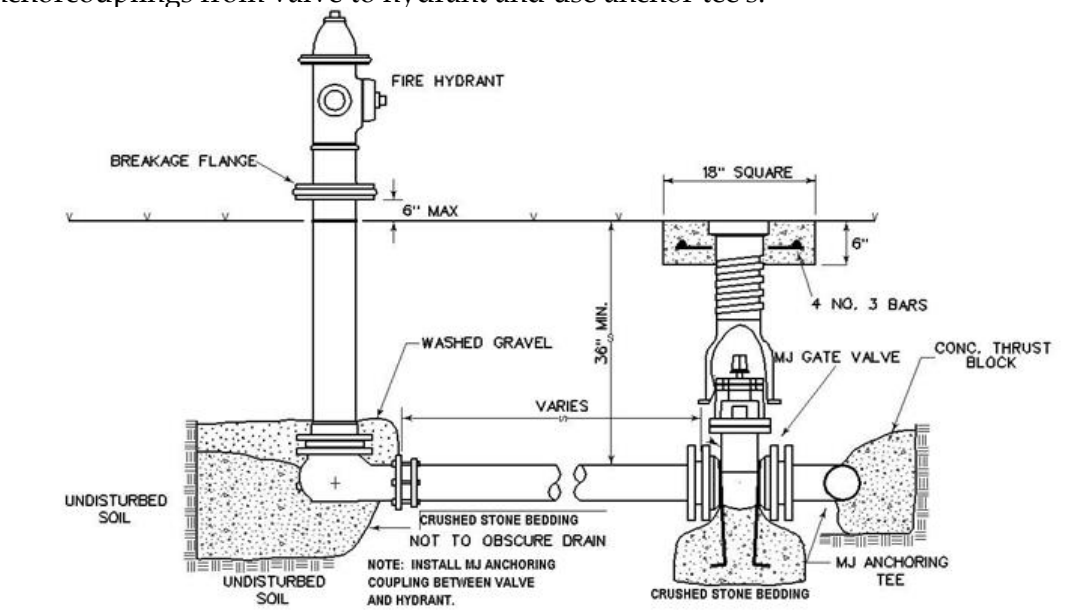

ILLUSTRATION 3.4.2. – FIRE HYDRANT INSTALLATION

PART 5 – WATER SERVICE CONNECTIONS

3.5.1. GENERAL

This standard covers the installation of a corporation stop in the water main, the water service line extending from the water main outward towards the road right-of-way line, and the meter valve at the line terminus.

3.5.2. CONNECTION TO MAIN LINES

Connection to water mains shall be made with the service line horizontal and watertight using an approved sealer on all screwed joints. Corporation stops shall be set in an up-45 degree position. Two-inch service lines shall be connected using brass connections or mechanical joint.



To Ductile Iron Mains: For three quarter inch (¾") and one inch (1") services, a bronze corporation stop with compression connection equal to Mueller H-15008 shall be installed in the main using a dry tap. For two inch (2") services, the bronze corporation stop shall be equal to Mueller H-15013 installed in a ductile iron tapped tee in the main.

To PVC Mains: For three quarter inch (¾") and one inch (1") services, a properly sized, hinged, single strap, bronze service clamp equal to Ford (#) series shall be installed with a bronze corporation stop with compression connection equal to Ford (#). For two inch (2") services the corporation stop equal to Mueller H-9969 shall be installed in a service tee.

3.5.3. SERVICE LINES

Service lines shall be flexible polyethylene tubing, SDR 9, per ASTM D2737 (PE3408) or Type K Copper per ASTM B88 For three quarter inch (¾") and one inch (1"). Two-inch (2") service lines shall be PVC pipe per the Water Pipe Line standard. All tubing and pipe shall have the manufacturer's name and NSF logo identification number. Generally, service lines shall be installed with a minimum bury of twenty-four inches (24") and shall be laid to conform roughly to the topography of the ground. Under ditches, the minimum bury shall be twenty-four inches (24") (measured from the bottom of the ditch). Trenching, backfilling, and pipe laying shall be performed in conformity with the Water Pipe Lines standard.

3.5.4. ENCASEMENTS

Encasement for service lines at roadway crossings shall be two inches (2") Schedule 40 PVC with solvent weld couplings. Trenching and backfilling shall be performed in conformity with the Water Pipe Lines standard.

3.5.5. SERVICE LINE TERMINALS

Each three quarter inch (¾") and one inch (1") service shall terminate with a bronze meter valve with compression connection/meter coupling equal to Mueller H-14348 and brass meter coupling equal to Mueller H-10890, set in a meter box near the right-of-way line. All joints shall be watertight.

For two inch (2") services a two inch (2") bronze meter valve with inside IPT/Meter-Flange equal to Mueller H-14337 shall be installed.

Meter boxes shall be plastic or any other approved or suggested type approved by the Public Works Director.

3.5.6. TRACER WIRE

Twelve gauge minimum insulated solid copper wire shall be installed with all plastic mains and service lines to facilitate location with a pipe locator. The tracer wire shall be laid in the trench with the pipe and threaded through encasements. Tracer wire shall be tied to the corporation stop, threaded through encasements where applicable and extended into the meter box. Tracer wire shall also be required on water connection service lines to the connection point at the structure.

3.5.7. FLUSHING

After completion of the service assembly installation, each service shall be thoroughly flushed with chlorinated water. During sterilization of the mains, the meter stop shall be opened to allow chlorinated water to pass through each service.

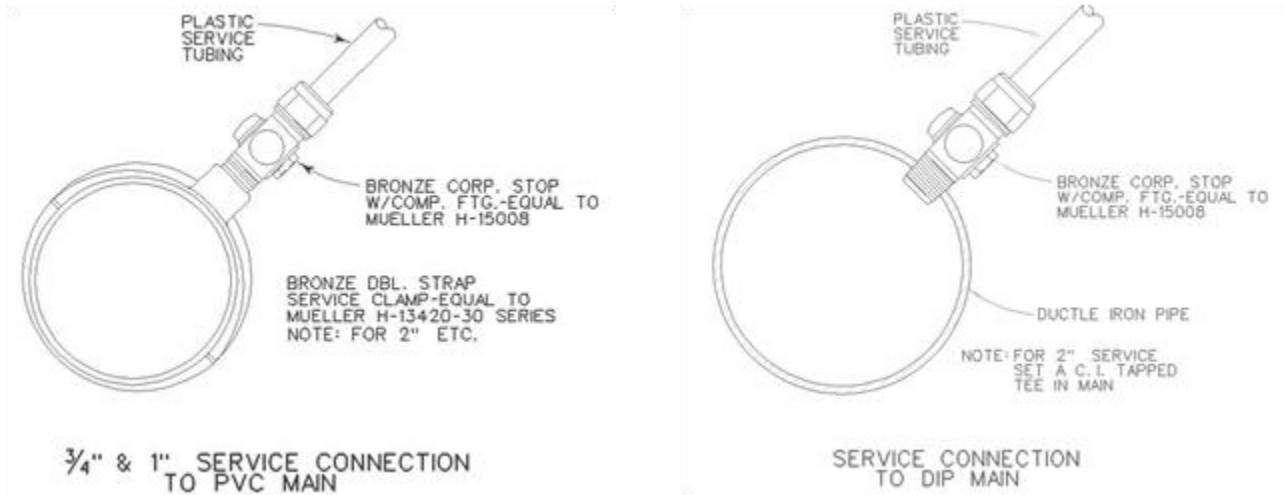

ILLUSTRATION 3.5.7.A. – SERVICE CONNECTION DETAILS

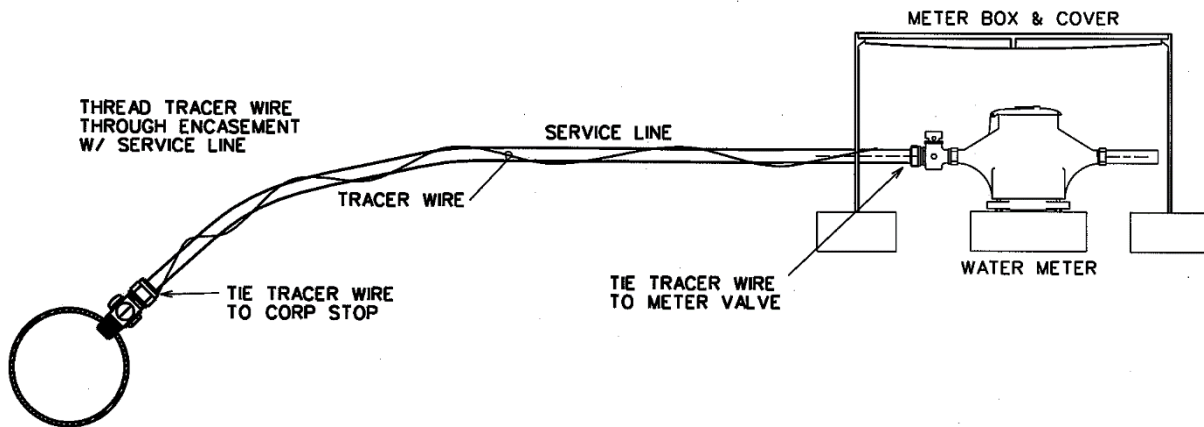

ILLUSTRATION 3.5.7.B. – WATER SERVICE LINE DETAILS

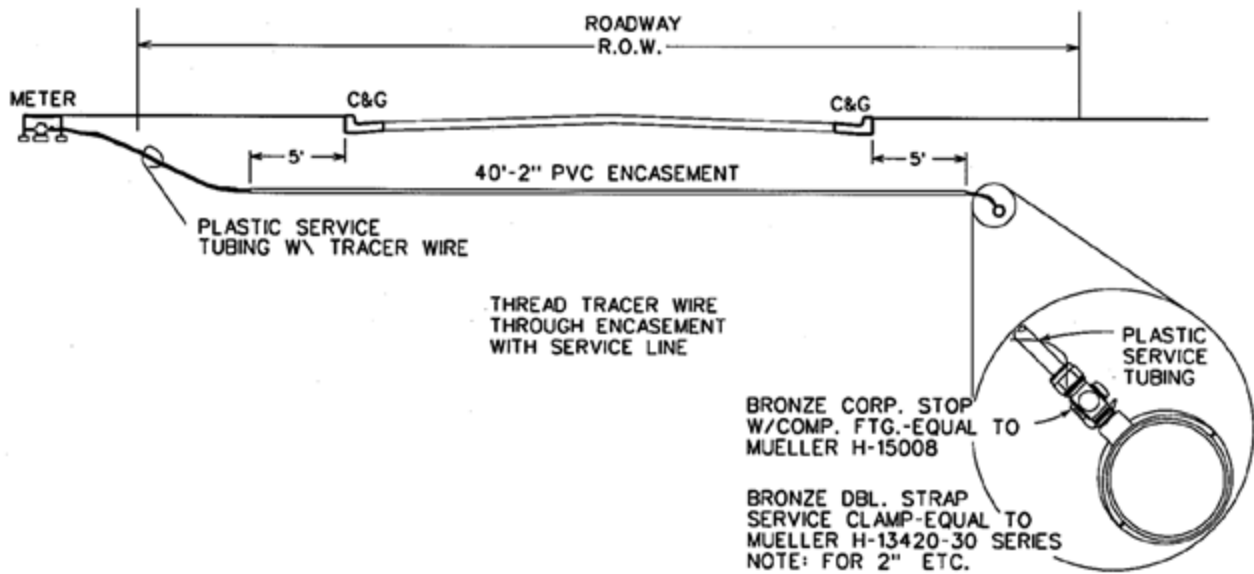

ILLUSTRATION 3.5.7.C. – SERVICE LINE ENCASEMENT DETAILS

PART 6 – CONNECTIONS TO EXISTING MAINS

3.6.1. GENERAL

Connections to existing water mains shall be made in cooperation with the Public Works Director. Schedule taps so as to interfere as little as possible with the operation of the system.

Connections to existing water mains shall be made as directed below:

- A. Connections to existing water mains shall be made by machine taps except as directed otherwise.
- B. A City permit will be required for each main line tap. The tap shall be made in the presence of a City employee after MSDH approval is provided.
- C. A connection fee will be required for each service tap.
- D. A City inspector must be present for each tap. No work will be permitted without an inspector present.
- E. All work shall conform to applicable requirements of this Ordinance and any other applicable City Ordinance.
- F. Surfaces shall be restored in accordance with City Standards.
- G. Damages shall be repaired at no cost to the City.

H. The developer's contractor shall be liable for the cost of the removal of contaminants introduced into the system as a result of the work.

NOTE: Where the water cannot be cut off on a line to be tapped, make the tap under pressure using a tapping sleeve and a tapping valve in accordance with the tapping machine manufacturer's instructions. It shall be the Contractor's responsibility to furnish the tapping machine required for a machine tap under pressure. Tapping sleeves for machine taps to ductile iron mains shall be iron body Mueller H-615 or approved equivalent. Tapping sleeves for machine taps to PVC mains shall be stainless steel body Mueller H-304, JCM432, or approved equivalent.

IN ADDITION: Valves for machine taps shall be resilient wedge tapping valves conforming to ANSI/AWWA C509 with stainless steel nuts and bolts on the stuffing box and valve bonnet. Mueller T-2360 MJFL, or approved equivalent.

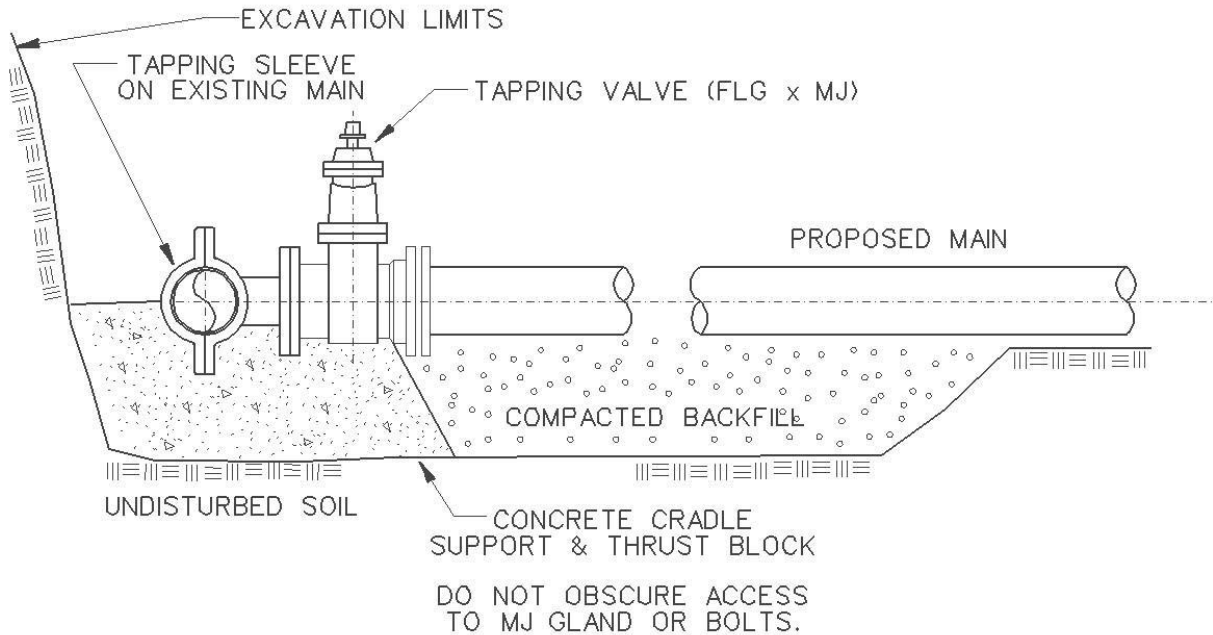

ILLUSTRATION 3.6.1. – MACHINE TAP DETAIL

PART 7 – WATER SYSTEM CONSTRUCTION RECORDS

3.7.1. REQUIREMENTS

The following records must be provided prior to approval of the Final Plat or release of the Construction Bond:

- A. A copy of the Mississippi State Health Department's final approval letter.



- B. A certification letter from the developer's engineer that the improvements were constructed in substantial conformance with the approved construction plans and specifications, accompanied by inspection documentation records and construction inspection photographs of all mechanical joints, assemblies and pipe deflection joints as constructed in the field. The developer, or his designee, is responsible for maintaining inspection records to ensure that all improvements were constructed according to approved plans.
- C. RECORD DRAWINGS shall accurately represent the completed construction including locations of service stub outs and appurtenances.
- D. RECORD DRAWINGS of the completed construction shall be provided in both hard copy and electronic formats. Provide four (4) printed sets and two (2) sets on CD or other media in PDF or other acceptable machine-readable file format.
- E. Copies of the manufacturer's literature necessary for reference in operating and maintaining the facilities including but not limited to manufacturer's product descriptive literature for materials incorporated into the work, operation and maintenance manuals for equipment, copies of basic warranty information, etc.
- F. Contact information for the source of supply.
- G. Copies of Mississippi State Department of Health bacteriological test results; and
- H. Other information as may be requested by the Administrator.

~END OF SECTION~

CHAPTER 4: SANITARY SEWER SYSTEMS

PART 1 – GENERAL REQUIREMENTS

The Sanitary Sewer System shall meet the requirements of the Department of Environmental Quality, Office of Pollution Control and conform to all applicable City of Saltillo standards.

The developer shall be fully responsible for the design, installation, and oversight of any necessary physical improvements to connect to existing public infrastructure.

4.1.1. PLANS AND SPECIFICATIONS APPROVAL

The Bureau of Environmental Quality, Office of Pollution Control requires:

"Plans and specifications for all proposed municipal and domestic sewage collection systems, including modifications and additions thereto, must be submitted to and approved by the Commission prior to beginning construction of the proposed system."

"All plans and specifications submitted to the Commission must be developed and submitted by a registered professional engineer."

4.1.2. SYSTEM DESIGN

Sewer mains shall be of sufficient size to serve all residents of the subdivision but shall not be less than eight inches (8") in diameter. The lines shall be designed and constructed to give mean velocities, when flowing full, of not less than two feet (2') per second, based on Kutter's formula using an "n" value of 0.013. Where velocities of over fifteen feet (15') per second are attained, special provision shall be made to protect against displacement. Sewers shall be laid with straight alignment and uniform slope between manholes.

Sewer mains and fittings may be constructed of Rigid Polyvinyl Chloride Pipe (PVC) or Ductile Iron Pipe (DI). Ductile iron pipe may be used in lieu of the above pipe materials.

Except for street and driveway crossings, sewer lines shall be located outside of paved areas. Exceptions will be considered on a case-by-case basis.

All sewers shall be designed to prevent damage from superimposed loads. Proper allowance for loads on the sewer shall be made because of the width and the depth of trench. Where necessary to withstand extraordinary superimposed loading, special bedding, concrete cradle, or special construction may be used.

Construction specifications shall contain appropriate requirements based on the criteria, standards and requirements of the City.

4.1.3. INSTALLATION

The width of the trench shall be ample enough to allow the pipe to be laid and jointed properly and to allow the backfill to be placed and compacted as needed. When wider trenches are dug, appropriate bedding class and pipe strength shall be used.



The installation of joints and the materials used shall be included in the specifications. Sewer joints shall be designed to minimize infiltration and to prevent the entrance of roots throughout the life of the system.

Manholes shall be installed: (1.) at the end of each line; (2.) at all changes in grade, size or alignment; (3.) at all intersections; and (4.) at distances not greater than four hundred feet (400') for sewers fifteen inches (15") or less, and five hundred feet (500') for sewers 18 inches to 30 inches (18" to 30"), except the distances up to six hundred feet (600') may be approved in special cases. Manholes shall be inspected for water-tightness prior to placing into service.

The minimum diameter of manhole shall be forty eight inches (48"). Manholes shall be of the pre-cast concrete (ASTM C478) or poured-in-place concrete type. Manhole steps shall be provided. Manholes shall be waterproofed on the interior and to twelve inches (12") below grade on the exterior.

The bottom of manholes shall be reinforced concrete and the flow channel (invert) through manholes shall be made to conform in shape and slope to that of the sewers.

Inlet and outlet pipes shall be jointed to the manholes with a gasketed flexible watertight connection that will allow differential settlement of the pipe and manhole wall to take place.

Watertight manhole covers shall be used for manholes (1) located in paved or traveled areas, (2) with tops set flush with the surrounding ground or (3) located in areas subjected to flooding by surface runoff or high water. The tops of manholes with vented covers shall be raised above the surrounding finished grade, three inches (3") minimum and shall not be subjected to surface runoff or flooding. Locked manhole covers may be required in isolated easement locations or where vandalism may be a problem. An access of twenty two inches (22") diameter (minimum) shall be provided.

Stub outs or house laterals (Schedule 40 PVC) shall be laid out and in place ahead of the gas and water lines so that variances in the depth or grade of the line will not be required to accommodate to allow for water or gas lines or stub outs. All sanitary sewer mains shall have stub outs installed, one per lot and be stubbed out to a sufficient distance to insure that the pavement of a street need not be cut in order to connect thereto. Each stub out shall include a service cleanout. **Multiple lots may not be serviced by a common service line.**

Sewers shall be laid at least ten feet (10') horizontally from any existing or proposed water main. The distance shall be measured edge to edge. In cases where it is not practical to maintain a ten foot (10') separation, the appropriate reviewing agency may allow deviation on a case-by-case basis. Sewers crossing water mains shall be laid to provide a minimum vertical distance of eighteen inches (18") between the outside of the water main and the outside of the sewer. The crossing shall be arranged so that the sewer joints will be equidistant and as far as possible from the water main joints. Where a water main crosses under a sewer, adequate structural support shall be provided for the sewer to prevent damage to the water main. When it is not possible to obtain proper horizontal and vertical separation as stipulated above, the sewer shall be designed and constructed equal to the water pipe, and shall be pressure tested to assure water tightness prior to backfilling.

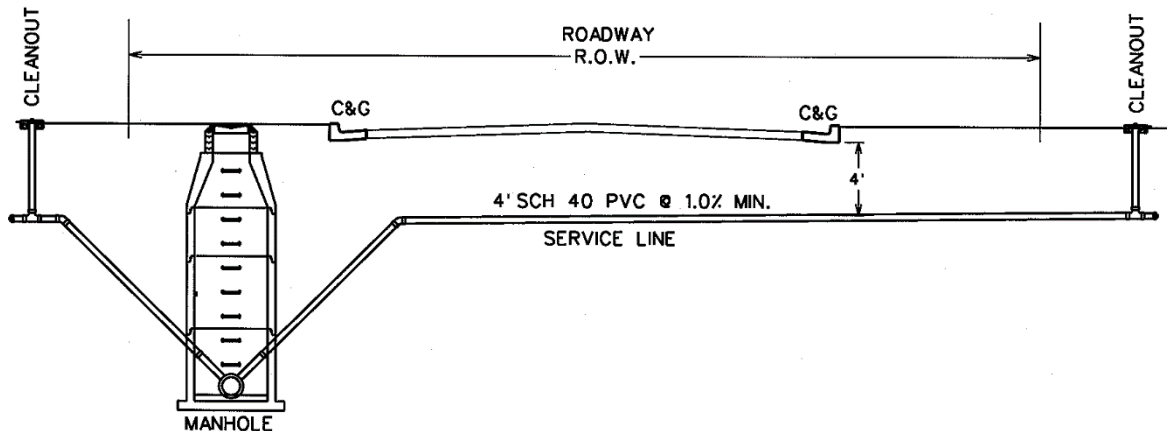

ILLUSTRATION 4.1.3. – SEWER SERVICE LINE DETAIL

PART 2 – GRAVITY SEWER LINES

4.2.1. MATERIALS

Sewer lines and fittings shall be PVC sewer pipe for sewer lines up to twenty seven inches (27") in diameter. Ductile iron pipe may be substituted for PVC pipe materials. PVC Sewer Pipe and fittings shall be rigid polyvinyl chloride pipe in accordance with ASTM Specification D-1784, cell classification 12454 and applicable portions of ASTM D-3034 for a pipe wall thickness will yield an SDR 35 rating and ASTM F-679 (PS46). The pipe shall have an integral bell for elastomeric gasket joints per ASTM 3212 with seals per ASTM F-477. All fittings and accessories shall have bell and spigot configurations identical to that of the pipe. Ductile Iron Pipe shall be in accordance with ANSI/ A21.50 and ANSI/ A21.51, shall be mechanical joint or push-on jointed and shall be cement lined in accordance with ANSI/ A21.4. Rubber gasket joints shall be in accordance with ANSI/ A21.11. Push-on joint pipe shall be used unless otherwise shown on the plans. Flanged joint pipe shall be in accordance with ANSI/ A21.10 and ANSI/ 21.15. The pressure classes for ductile iron sewer line shall be: PC 350 for eight to twelve inch (8"-12") pipe, PC 250 for fourteen to twenty inch (14"-20") pipe, PC 200 for twenty four inch (24") pipe and PC 150 for thirty inch (30") pipe.

4.2.2. PIPE MATERIAL TESTING

Each piece of pipe and fitting shall bear the stamp of certification of the manufacturer that the pipe conforms to the standard specifications requirements.

4.2.3. INSTALLATION

PVC sewer pipe shall be installed in accordance with ASTM Standard D-2321 as modified herein. PVC pipe shall be installed within one (1) year of the date of manufacture indicated on

the pipe. Ductile iron pipe shall be installed in accordance with ASTM A746 (Type 4) except that stone bedding will not be required of pipe size twelve inches (12") or less.

A. BEDDING AND HAUNCHING

Crushed stone, sand, or other approved equal shall be used to support the pipe as shown on the drawing of typical trench section in this standard. Prior to pipe installation, the bedding material shall be brought to grade along the entire length of pipe to be installed. For pipe with bells or couplings, bell holes shall be formed at each joint to provide full length support and prevent point loadings.

B. PIPE LAYING

The necessary equipment and supports shall be provided to insure installation of the pipe to the proper line and grade. The pipe shall be lowered into the trench so that neither the pipe nor the trench will be damaged. The pipe shall be protected from lateral displacement. The pipe shall not be laid in water. The pipe shall be laid in the finished trench starting at the lowest point and laying the pipe upgrade. The pipe shall be set firmly and accurately, with ends abutting, to line and grade so that the invert will be smooth and uniform. The pipe lines shall be drained as the work progresses so that no water will be trapped in the lines. Tracer wire is required on all gravity mains.

C. MAKING JOINTS

Joints shall be watertight in accordance with the jointing standards of the manufacturer. All oil, grease, asphalt, mud, and debris shall be cleaned from the joint before it is made. Solvents or lubricant shall be applied as required. The pipes shall be pressed home using mechanical means if necessary so that a full bearing surface is obtained all around the joint. Out-of-round sections shall be culled.

D. CONNECTIONS

Connections to manholes or other structures shall be watertight and shall conform to a smooth and uniform flow line. Commercial lengths of pipe shall be cut along neat lines as required. All gravity sewer lines shall begin and end at a manhole.

E. BACKFILLING

Trenching and excavations shall be backfilled immediately after the pipe are laid.

In unpaved areas, the backfill may be excavated materials except that debris, frozen materials, large clods or stones, organic matter or other unsuitable materials shall not be used for backfill within two feet (2") of the top of the pipe. The initial backfill shall be placed in six inch (6") lifts. Each lift shall be thoroughly and carefully tamped before the next layer is placed. The remainder of the backfill may be accomplished with bulldozers and tampers by dozing twelve inch (12") thick layers into the trench then tamping each layer firmly before placing the next layer. A windrow shall be left over the trench and bladed and shifted as necessary when settling has occurred. For graveled areas, after maximum settlement has been reached, excess material shall be hauled away and washed gravel or crushed stone added as necessary.

The areas to be paved, the trench soils shall be tested by the design Engineer to determine their suitability for use as backfill material. If the trench soils are found to be unsuitable they shall be replaced with suitable materials. Backfill in areas to be paved shall be placed in twelve inch (12") lifts and each lift compacted to ninety five percent (95%) Standard Proctor density. Backfill shall extend to the top of the subgrade.

F. WYE OR TEE BRANCHES

The wye or tee Branches shall be of the same material and size as the sewer line, the branch opening shall be six inch (6") or four inch (4"). Branches shall be installed in the "up 45 degree" position. A watertight plug shall be set in each branch unless a service line is attached at the time of construction. The plug shall be set so that removal will not injure the wye or tee. Each branch without a service line attached shall be permanently marked on top of the curb for ease of future location.

G. TESTING

Deflection Testing: The alignment and grade of sewer pipe intended to be straight shall be so true that a section of laid line will show a full circle of light when viewed from the other end. PVC sewer pipe shall be tested after backfill and trench settlement (but not less than thirty (30) days after installation) with an approved go/no-go five percent (5%) deflection testing mandrel. The mandrel shall be pulled by hand without mechanical pulling devices.

Leakage Testing: Infiltration/exfiltration shall not exceed fifty (50) gallons per inch of pipe diameter per mile per day for any section of the system. Test all pipe lines for infiltration/exfiltration using the air test method described in ASTM F1417, "Standard Testing Method for Installation Acceptance of Plastic Gravity Sewer Lines using Low-Pressure Air."

The air test procedure shall be as follows:

- 1) Clean the section of pipe to be tested using an approved method.
- 2) Plug all pipe outlets with suitable test plugs. Brace each plug securely.
- 3) The seal at one end of the pipe section being tested shall have an orifice through which air can be injected into the pipe. The air supply line shall contain an on-off air valve and a pressure gauge. The pressure gauge shall have minimum division of 0.10 psi and shall have an accuracy of +five percent (+5%).
- 4) If the pipe section being testing is submerged in water, insert a pipe probe, by boring or jetting, into the backfill material adjacent to the center of the pipe and determine the pressure in the probe when air passes slowly through it, which is the back pressure due to ground water submergence. Increase all gauge pressures in the test by this amount. Alternately, if the depth of pipe submergence below the ground water is known, gauge pressures may be adjusted by adding 0.433 psi for each foot of submergence.
- 5) Add air slowly to the portion of the pipe installation under test until the internal air pressure is relaxed to four (4.0) psi.



- 6) Check exposed pipe and plugs for abnormal leakage by coating with a soap solution. If any failures are observed, bleed off air and make necessary repairs.
- 7) After an internal pressure of four (4.0) psi is obtained, allow at least two (2) minutes for air temperature to stabilize, adding only the amount of air required to maintain pressure.
- 8) After the two minute period, disconnect air supply.
- 9) When pressure decreases to three and a half (3.5) psi, start stopwatch. Determine the time in seconds that it required for the internal air pressure to reach two and a half (2.5) psi. This time interval should then be compared with the time required by specification in the Low Pressure Air Sewer Test table in these specifications.
- 10) If the time lapse is greater than that specified for the section undergoing test has passed, then that section has passed the test and the test may be discontinued at that time. However, if the time is less than that specified, the line has not passed the test and the Contractor will be required to repair and prepare the line for retest.
- 11) A City representative must be present to witness the tests.

TABLE 4.2.3. PRESSURE TEST ALLOWANCES

MINIMUM SPECIFIED TIME REQUIRED FOR A 1.0 PSIG PRESSURE DROP FOR SIZE AND LENGTH OF PIPE INDICATED FOR Q=0.0015 CFM/SF

Pipe Dia. In.	Time, mins.	Min. Time, ft.	Longer Length's	100'	150'	200'	250'	300'	350'	400'	450'
4	3:46	597	0.380 L	3:46	3:46	3:46	3:46	3:46	3:46	3:46	3:46
6	5:40	398	0.854 L	5:40	5:40	5:40	5:40	5:40	5:40	5:42	6:24
8	7:34	298	1.502 L	7:34	7:34	7:34	7:34	7:36	8:52	10:08	11:24
10	9:26	239	2.374 L	9:26	9:26	9:26	9:53	11:52	13:51	15:49	17:48
12	11:20	199	3.418 L	11:20	11:20	11:24	14:15	17:05	19:56	22:47	25:38
15	14:10	159	5.342 L	14:10	14:10	17:48	22:15	26:42	31:09	35:36	40:04
18	17:00	133	7.692 L	17:00	19:13	25:38	32:03	38:27	44:52	51:16	57:41
21	19:50	114	10.470 L	19:50	26:10	34:54	43:37	52:21	61:00	69:48	78:31
24	22:40	99	13.674 L	22:47	34:11	45:34	56:58	68:22	79:46	91:10	102:33
27	25:30	88	17:306 L	28:51	43:16	57:41	72:07	86:32	100:57	115:22	129:48
30	28:20	80	21.366 L	35:37	53:25	71:13	89:02	106:50	124:38	142:26	160:15
33	31:10	72	25.852 L	43:05	64:38	86:10	107:43	129:16	150:43	172:21	193:53
36	34:00	66	30.768 L	51:17	76:55	12:34	128:12	153:50	179:29	205:07	230:46

NOTE: Consult with pipe and appurtenance manufacturer for maximum test pressure for pipe size greater than 30 inches in diameter.

4.2.4. FLUSHING

The completed gravity sewer lines shall be free of all mud, siltation, and other foreign matter deposited or collected during construction. The lines shall be flushed prior to testing. Flushing shall be started at the upstream end of the completed system and shall continue downstream manhole to manhole. Water used in flushing shall not be permitted to enter into the system but shall be collected and disposed of in an approved manner. Also mud and other solids shall be similarly collected and disposed of.

4.2.5. VIDEO INSPECTION AND RECORDS

Prior to acceptance of the sewer system, the City shall require video records to prove that the system has been installed in accordance with these guidelines. Closed circuit television or other method shall be used to record the condition of each segment of gravity sewer line. A City representative must be present while video scoping takes place. Provide a DVD recording for each segment of gravity sewer line. A camera capable of pan and tilt shall be used to document the location and condition of each sewer connection. The location of service connections shall be indicated by measured distance from the downstream manhole.



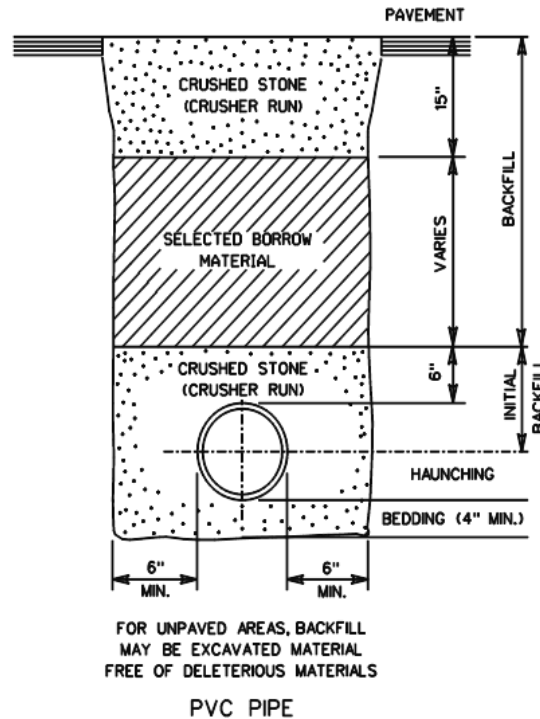

ILLUSTRATION 4.2.5. – SEWER LINE TYPICAL BACKFILL DETAILS

PART 3 – SEWER SERVICE LINES

4.3.1. MATERIALS

Sewer service lines and fittings shall be either PVC or DIP sewer pipe.

PVC Sewer Pipe and fittings shall be Schedule 40 rigid polyvinyl chloride pipe in accordance with ASTM Specification D-1784, (cell classification 12454) and ASTM D-2665.

Ductile Iron Pipe for sewer service lines shall be PC 350 in accordance with ASTM A746 and shall be cement lined in accordance with ASTM A21.4. Push-on joints shall be in accordance with ASTM A21.11.

4.3.2. CONSTRUCTION

Service lines shall be laid to the same requirements as specified for Gravity Sewer Lines. All pipe must be laid to a positive grade; with minimum slope of one foot (1') per one hundred feet (100'). Services lines shall terminate to such an elevation that the abutting premises may be served as intended.

- Adapters required to make a watertight connection to the wye or tee branch and elbows as required for proper service shall be installed.
- Each service line shall incorporate a cleanout as indicated. Tracer wire shall be installed from the sewer tap to the cleanout. Tracer wire shall also be required on sewer connection service lines.

- The end of each new service not connected to a house service line shall have a watertight plug installed in such a manner that the plug may be removed without injury from the pipe. The plug shall be blocked or secured in such a manner that testing can be completed as specified for Gravity Sewer Lines.
- The end of each new service shall also be clearly marked by a 4" x 4" x 36" treated post, or a "T" post, which may be removed after the service connection has been completed.

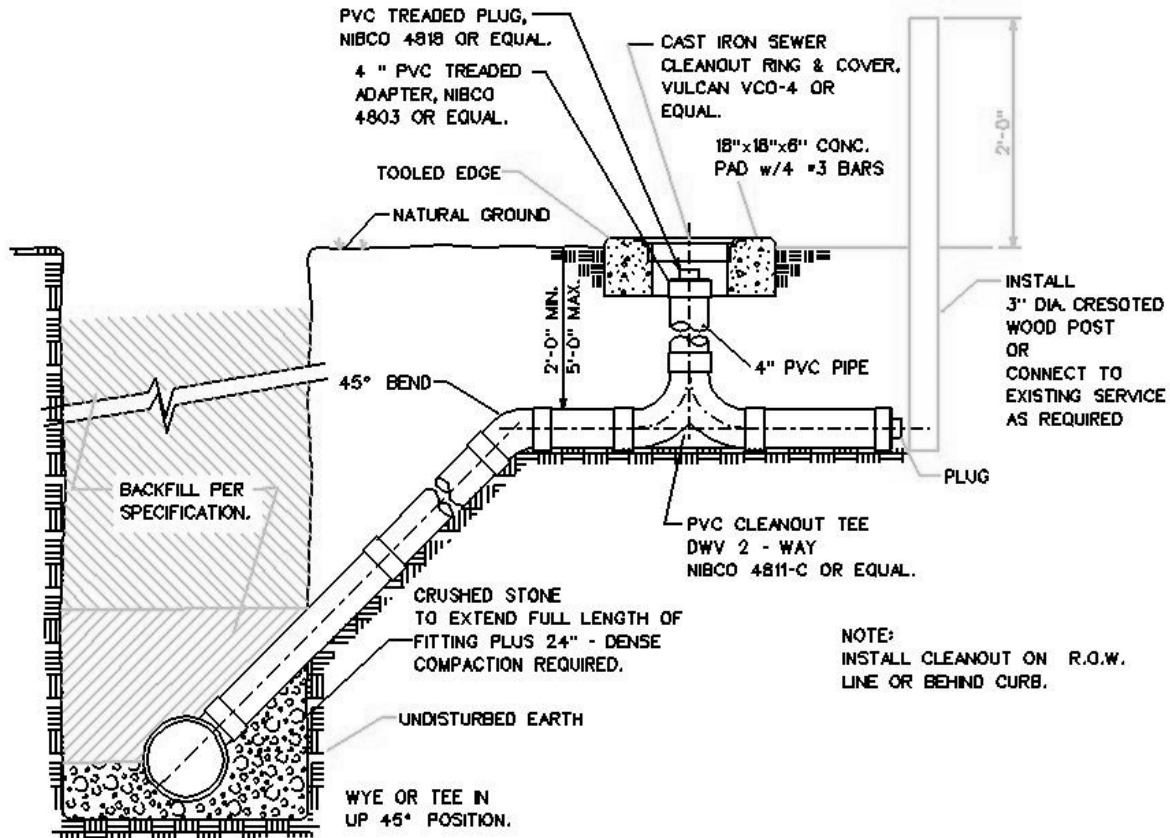

ILLUSTRATION 4.3.2. – TYPICAL CLEANOUT INSTALLATION DETAIL

PART 4 – SEWER MANHOLES

4.4.1. MATERIALS

Manhole barrels may be constructed of precast concrete manhole units or concrete poured-in-place. The bottom of all manholes shall be reinforced concrete.

Precast concrete manholes shall conform to the requirements of ASTM C-478 and shall be constructed using concrete with a minimum twenty eight (28)-day compressive strength of four thousand (4000) psi. The mixture shall contain not less than six (6) bags of Portland Cement per cubic yard.

Rubber gaskets shall conform to the requirements of the latest edition of ASTM Specification C-443. Lubricants shall be as recommended by the gasket manufacturer.

Manhole pipe seal gaskets for precast manhole units shall be similar to "Kor-N-Seal" as manufactured by the Kor-N-Seal Co., Milford, NH.

Preformed joint compound shall be a butyl compound similar to "EZ Stik" as manufactured by Concrete Products Supply Co., Fort Wayne, IN. Primer, when required for use with the preformed joint compound, shall be as recommended by the manufacturer of the joint compound.

Sealer compound shall be similar to "Drycon" as manufactured by IPA Systems, Inc., Philadelphia, PA or Tamm's "Tamosel".

Patching material shall be similar to "Octocrete" as manufactured by IPA Systems, Inc., Philadelphia, PA or Tamm's "Speed Crete Blue Line".

Manhole steps shall be made of injection molded copolymer polypropylene encapsulating a one half inch ($\frac{1}{2}$ ") diameter grade sixty (60) steel reinforcing rod. The steps shall be of such cross-sectional area and configuration that they will withstand a single concentrated live load of three hundred pounds (300 lbs.). They shall be in conformance with *ASTM Standard C-478 Paragraph 11* except as herein modified.

Manhole frames and covers shall be sound gray iron castings (ASTM A48 Class 30B). The castings shall be true to pattern, free from faults, sponginess, cracks, blowholes, and other defects affecting their strength. The minimum clear opening shall be twenty two inches (22") in diameter. The frame and cover shall be machined to a non-rattle fit. The standard manhole frame and cover for installations not subject to flooding, may be non-traffic type weighing approximately three hundred pounds (300 lbs.).

Manhole frames and covers for manholes in streets and paved areas shall be watertight traffic model type; similar to Vulcan Pattern V-2407-2 pattern without vent holes and weighing approximately three hundred fifty pounds (350 lbs.). The cover shall have a rubber "O" ring gasket and be fastened to the ring with four stainless steel hexagonal-head bolts.

Covers for areas subjected to runoff shall be watertight.

Manhole covers shall have the word "SANITARY SEWER" cast into the face.

4.4.2. CONSTRUCTION

Manhole inverts shall be constructed on line and grade of concrete, concrete and split pipe or with invert builder blocks and mortar. The invert shall be formed smoothly and accurately so as to assure the free, unobstructed flow of sewage through the manhole.

Precast manholes shall be constructed of precast units with concrete bottoms. The bottom unit shall be set level on a six inch (6") layer of medium crushed stone bedding. The frame shall be placed on a grout bed or a grout and brick riser. Joints in brick risers shall not exceed five eights inch ($\frac{5}{8}$ ") in thickness. Exterior joints of manhole units shall be wiped with grout and sealed entirely inside and outside with sealer compounds. The exterior surface may be sealed prior to installation.

Poured in place manholes shall be constructed in accordance with the manufacturer's requirements. Form fins shall be removed on the entire interior and, on the exterior, to below one-foot grade. The inside of these manholes shall be sealed with sealer compounds.

After installation, the manhole interior shall be coated with two (2) one sixteenth inch (1/16") thick coats of sealer compound. The exterior shall be coated in the same manner to twelve inches (12") below finished grade.

"Doghouse" style manholes will not be allowed unless authorized by the City.

Manhole steps shall be installed at sixteen inches (16") o.c. vertically. The deepest step shall be located not more than twenty four inches (24") above the manhole invert.

The cast iron frame and covers shall be installed to grade, set in a grout bed. Grout shall lap up one inch (1") minimum on the frame vertical. In streets, the manhole covers shall be set no more than to one inch (1") above the street grade and parallel to the plane of the street.

All visible leaks in manhole bottoms, barrels, and connection shall be stopped.

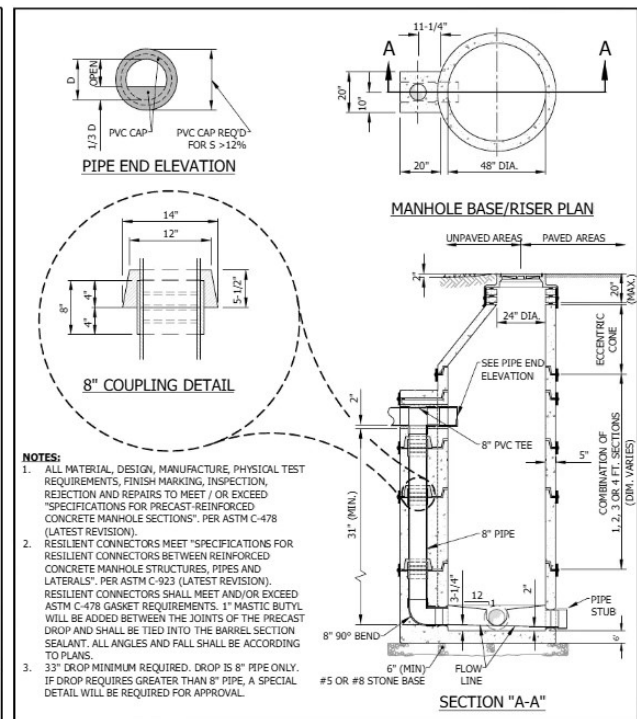
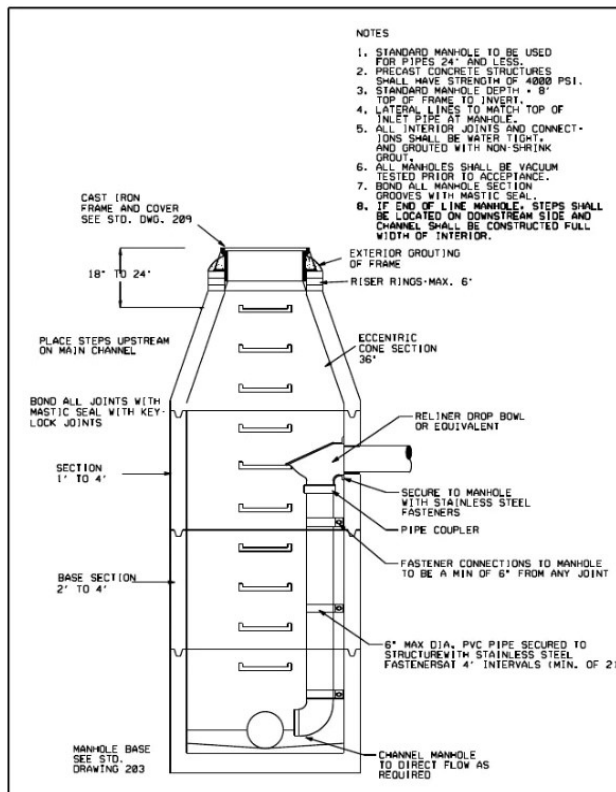

- NOTES:**
- ALL MATERIAL, DESIGN, MANUFACTURE, PHYSICAL TEST REQUIREMENTS, FINISH MARKING, INSPECTION, REJECTION AND REPAIRS TO MEET OR EXCEED "SPECIFICATIONS FOR PRECAST-REINFORCED CONCRETE MANHOLE SECTIONS", PER ASTM C-478 (LATEST REVISION).
 - RESILIENT CONNECTORS MEET "SPECIFICATIONS FOR RESILIENT CONNECTORS BETWEEN REINFORCED CONCRETE MANHOLE STRUCTURES, PIPES AND LATERALS", PER ASTM C-923 (LATEST REVISION). RESILIENT CONNECTORS SHALL MEET AND/OR EXCEED ASTM C-478 GASKET REQUIREMENTS. 1" MASTIC BUTYL WILL BE ADDED BETWEEN THE JOINTS OF THE PRECAST DROP AND SHALL BE TIED INTO THE BARREL SECTION SEALANT. ALL ANGLES AND FALL SHALL BE ACCORDING TO PLANS.
 - 33" DROP MINIMUM REQUIRED. DROP IS 8" PIPE ONLY. IF DROP REQUIRES GREATER THAN 8" PIPE ONLY, A SPECIAL DETAIL WILL BE REQUIRED FOR APPROVAL.



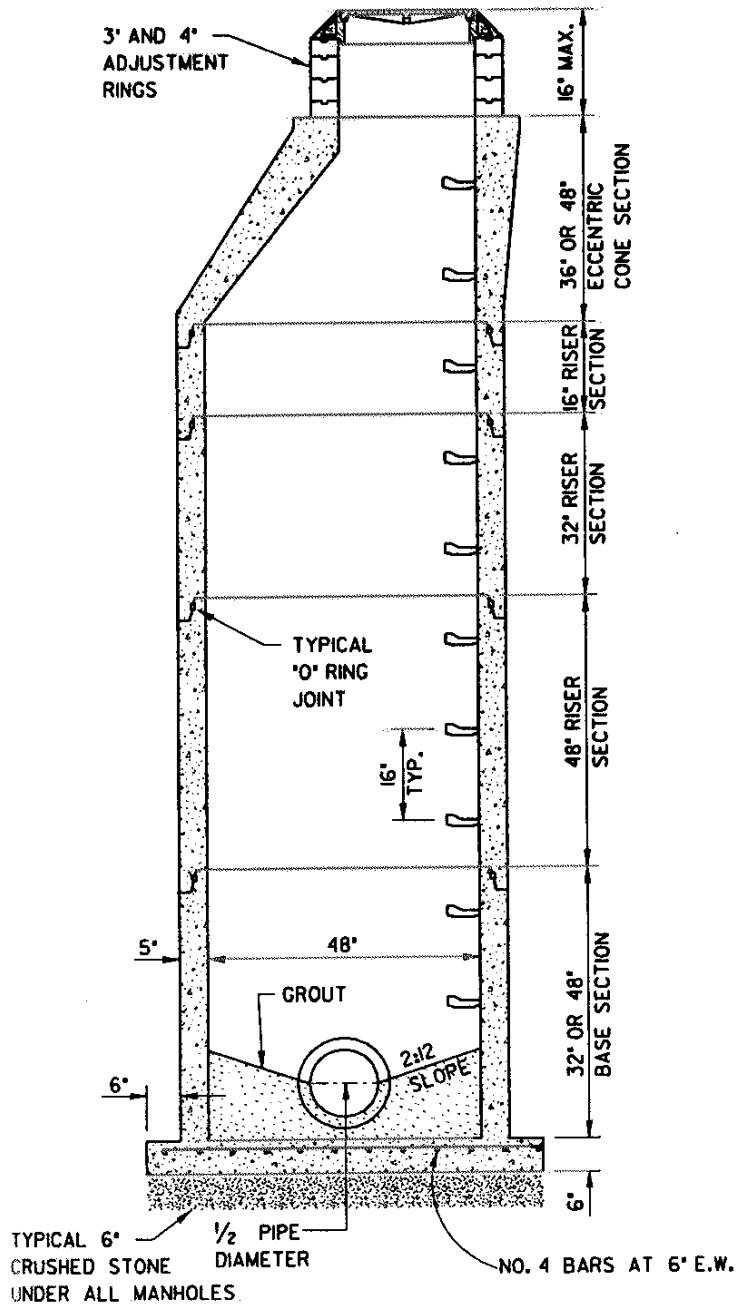
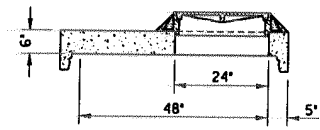
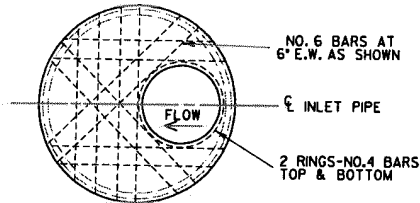

ILLUSTRATION 4.4.2. – SEWER MANHOLE DETAILS



FLAT TOP MANHOLES



FLAT MANHOLE TOP REINFORCING

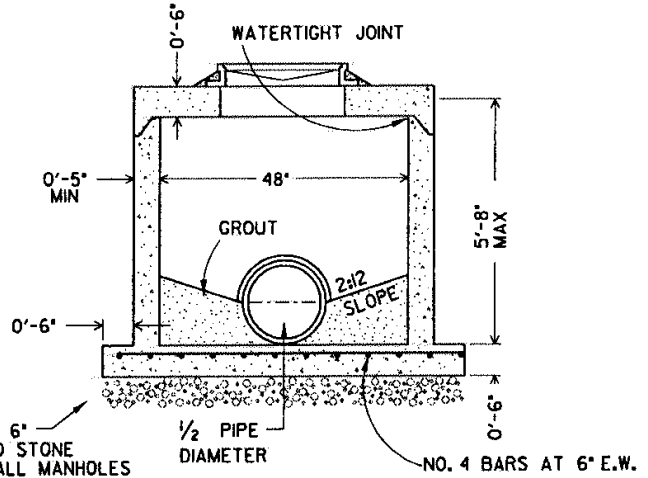

SHALLOW MANHOLE

ILLUSTRATION 4.4.3. – SEWER MANHOLE DETAILS

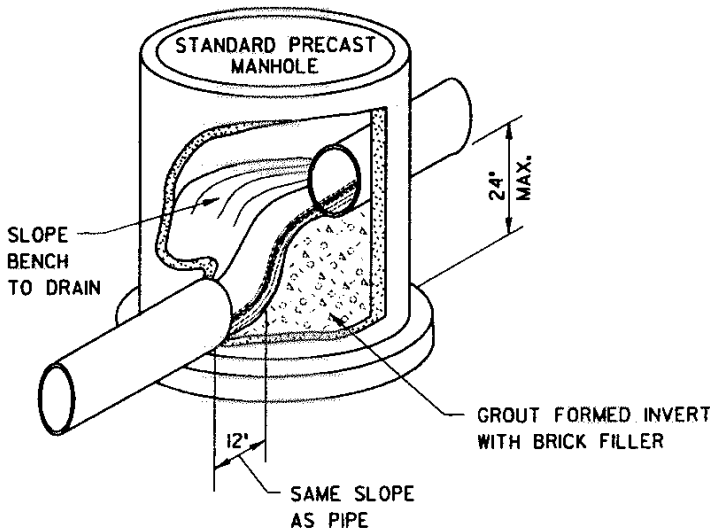

ILLUSTRATION 4.4.4. – SEWER MANHOLE DETAILS

PART 5 – SEWAGE LIFT STATIONS

4.5.1. GENERAL

Sewage lift stations are not encouraged, but will be permitted where gravity sewer options are unavailable. The burden of proof shall be on the applicant to show that all other options have been reviewed and that a station is necessary. Where lift stations are proposed, the applicant

must consider future development of city infrastructure and expansion options of adjacent properties when specifying the proposed system.

Sewage Lift Stations shall be factory built and tested as complete units and shall meet the requirements of the Mississippi Department of Environmental Quality Guidelines as modified herein.

The discharge from the Sewage Lift Station shall be routed to a point on the City's collection system that is acceptable to the City.

Sewage Lift Stations shall be designed for above ground suction lift pumps where hydraulically feasible. Other types of pumps will be considered on a case-by-case basis only.

Sewage Lift Stations shall be prefabricated stations manufactured by the Gorman-Rupp Company of Mansfield, Ohio and must have a secondary (backup) pump that is equipped with an alarm to notify officials in the event of failure.

Design calculations shall be provided for all Sewer Lift Stations.

4.5.2. FEATURES

Control panels shall be fabricated by the Lift Station manufacturer. Control Panels shall be equipped with City approved electric surge protection for main and branch circuits. An automatic pump alternator shall be provided with a manual lead/lag selection switch. A run light and elapsed time meter for each pump shall be included in the control panel. An adjustable high water visual/audible alarm with silencing switch shall be provided.

Wet wells shall be constructed of reinforced concrete pipe ASTM C-76, Class III, Wall B.

Station piping shall be ductile iron with flanged connections. Stainless steel bolts shall be used for securing flanged connections located within the wet well.

If submersible pumps are approved, discharge valve arrangements shall be installed in a separate vault accessible from ground level. Valve vaults shall have bottoms sloped to drain and the drain (if routed to the wet well) shall be fitted with a pinch type check valve to prevent water from entering the vault from the wet well. Separate conduits with seal fitting are required for each power conductor and float switch cable. Conduits shall be extended from the control panel to the wet well and shall be fitted with seal fitting on the inside of the wet well. Conduit ends in the wet well shall be set within easy reach from above ground but in no case more than eighteen inches (18") below the top of the wet well.

4.5.3. LIFT STATION SYSTEM START UP

The developer shall arrange for a factory trained representative to perform field-testing and to instruct City operating personnel in the operation and maintenance of the sewage lift station.

A manufacturer's O & M Manual shall be provided for each sewage lift station.

4.5.4. ACCESS

Access to within ten feet (10') of the lift station shall be by paved access road. Access roadways shall be constructed as set out for local streets, except that access roads widths shall be twelve feet (12'). Curb and gutter are not required for the access road.

4.5.5. SECURITY

All lift stations shall be fenced for security. Landscaping, shrubs, and/or architectural treatments for concealing lift station equipment are encouraged, but shall not be set closer than ten feet (10') to the station enclosure and shall not obscure access. Structures to enclose pumping equipment shall be considered for approval on a case-by-case basis. Security fencing must be dark colored, vinyl-coated chain link, or approved equal with a minimum height of six feet (6').

4.5.6. STRUCTURES

Permanent structures for lift stations are required to match adjacent architecture styles, or character, or must be fully screened by an evergreen buffer with a minimum height of six feet (6') at the time of installation.

PART 6 – PRESSURE SEWER LINES

4.6.1. MATERIALS

Plastic Pipe shall be rigid polyvinyl chloride pipe in accordance with ASTM Specification D1784 (Cell Classification 12454). Pipe shall be Class 200 (SDR 21) per ASTM D-2241 with gasketed slip joints. "O"-ring joints will not be accepted. Gasket joints shall be in accordance with ASTM D-3139.

Ductile Iron Pipe for pressure sewer lines shall be in accordance with ANSI/A21.50 and ANSI/A21.51, mechanical or push-on jointed and shall be cement lined in accordance with ANSI/A21.4. Rubber gasket joints shall be in accordance with ANSI/A21.11. Push-on joint pipe shall be used unless otherwise shown on the plans. Flanged joint pipe shall be in accordance with ANSI/A21.10 and ANSI/21.15.

Restrained Joint Pipe shall be rated for 250-PSI minimum. The joints, gaskets, and accessories for restrained joints shall meet applicable requirements of ANSI/A21.11. Retainer glands for mechanical joint pipe shall be Megalug Ebba Iron or Uni-Flange Series 1400 restrained joint devices.

Restraint Devices for PVC Pipe shall be manufactured of ductile iron conforming to ASTM A-536. Bolts and connecting hardware shall be in accordance with ASNI A21.11. All restraint devices shall have a pressure rating equal to that of the pipe on which it is used. Restraint devices shall be Uni-Flange Block Buster Series 1300, Ebaa Iron Series 2000PV, or City approved equal.

Fittings for ductile iron pipe and two inch (2") and larger PVC pipe shall be ductile iron mechanical joint fittings, ANSI Specifications A21.53, A21.10, and A21.11. Ductile iron fittings shall be cement-mortar lined per ASTM specification A21.



4.6.2. CONSTRUCTION
A. JOINTING

Ductile Iron Pipe - In general all joints shall be in accordance with the manufacturer's instructions exercising extreme care to clean all parts before assembly. Make all joints under dry conditions. Wrap underground flanges with eight (8) mil black polyethylene material conforming to ANSI A21.5 and tape in place before backfilling.

Plastic Pipe - Joints in plastic pipe shall be rubber gasket push-on type. Make push-on joints in accordance with the manufacturer's instructions. The resulting joint shall be clean and watertight.

B. PIPE LAYING

The pipe shall be lowered into the trench in such a manner as to prevent damage to the pipe or pipe coating. It shall not be dropped or dumped during unloading or laying. Foreign mater and dirt shall be prevented from entering the pipe. A minimum cover of thirty-six inches (36"), measured from the top of the pipe shall be provided. Plastic pipes not encased and under vehicular grade paved streets shall be covered at least forty-eight inches (48").

C. CONCRETE THRUST BLOCK

Concrete thrust blocks shall be provided at all bends in pipe lines greater than twenty two and a half (22-1/2) degrees. Blocks shall bear on compacted natural soil of trench walls and bottoms and shall provide a square bearing surface opposite the direction of pipe run of the following dimensions:

Bearing Surface Side

<u>Bend</u>	<u>Pipe Diameter (inches)</u>
30°	1
45°	2
90°	4

D. TWELVE GAUGE WIRES

Twelve gauge minimum insulated solid single-strand copper tracer wire shall be installed with all plastic mains and service lines to facilitate location with a pipe locator. The tracer wire shall be laid in the trench with the plastic pipe.

The tracer wire shall be brought up and terminated in a tracer wire test station at each valve and at intervals along pipe lines not to exceed five hundred feet (500'). Tracer wire test stations shall be Rhino TriView Flex with internal test station as manufactured by REPNET, Inc. or equal. The tracer wire station shall be installed by sliding it over a six feet (6') long 1-1/2 lb. per foot U-channel post driven eighteen to twenty four inches (18"-24") into the ground and

securing it with a bolt or rivet as recommended by the manufacturer. Identification decals shall be affixed to all three sides of the post.

E. UNDERGROUND WARNING TAPE

Warning tape shall be installed in the trench above the pressure sewer lines after the initial backfill is placed and compacted. Underground warning tape shall be manufactured of polyethylene, green in color, and imprinted with the words "CAUTION - BURIED SEWER LINE BELOW". Underground warning tape shall be four (4) mils thick and three inches (3") wide as manufactured by SETON Identification Products, Branford, CT or approved equal.

F. BACKFILLING

Trenching and excavations shall be backfilled immediately after the pipes are laid. The initial backfill shall extend to twelve inches (12") above the pipe. The initial backfill shall be thoroughly and carefully tamped before the next layer is placed. The remainder of the backfill shall be as follows:

In areas not to be paved the backfill may be fine, loose soil, free from large clods, stones, frozen earth, debris, or any material with an exceptionally high void content. The backfill may be accomplished by dozing in layers of approximately one foot (1') each. A windrow shall be left over the trench and bladed and shifted as necessary when settling has occurred. For graveled areas, after maximum settlement has been reached, excess material shall be hauled away and washed gravel or crushed stone added as necessary.

In areas to be paved, the trench soils shall be tested by the design engineer to determine their suitability for use as backfill material. If the trench soils are found to be unsuitable, they shall be replaced with suitable materials. Backfill in areas to be paved shall be placed in twelve inch (12") lifts and each lift compacted to ninety five percent (95%) Standard Proctor density. Backfill shall extend to the top of the subgrade.

G. TESTING

Pressure sewer lines shall be hydrostatically tested to a pressure of one hundred fifty (150) psi. The duration of the test at the test pressure shall be at least one (1) hour. Pipe lines showing any leakage as evidenced by a reduction in pressure will not be accepted. Defective pipe or fittings shall be removed and replaced with sound material and the test repeated until satisfactory results are obtained.

Before applying the specified test pressure, all air shall be expelled from the pipe. If blow-offs are not available at high places, taps shall be made at points of highest elevation before the test is made. Each section of pipe shall be slowly filled with water to the specified test pressure, based on the elevation of the lowest point of the line or lowest point of the section under test and corrected to the elevation of the test gauge. Pressure shall be applied by means of a test pump connected to the pipe in an approved manner. Make arrangements for metering the amount of water used during the testing.



All testing must be conducted in the supervision of the City Engineer or City Building Inspector.

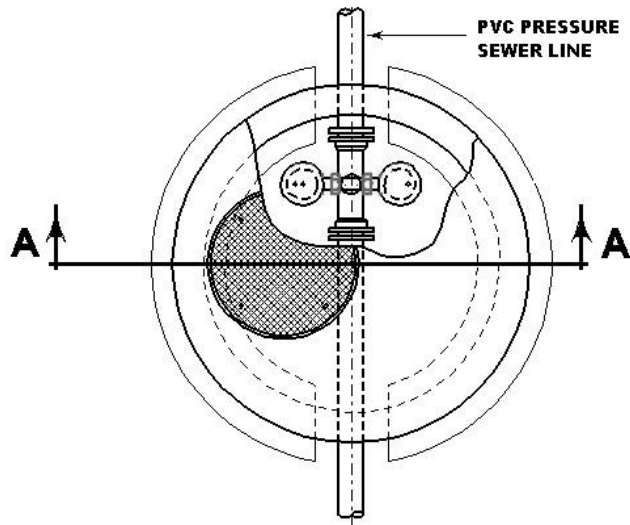

PLAN VIEW

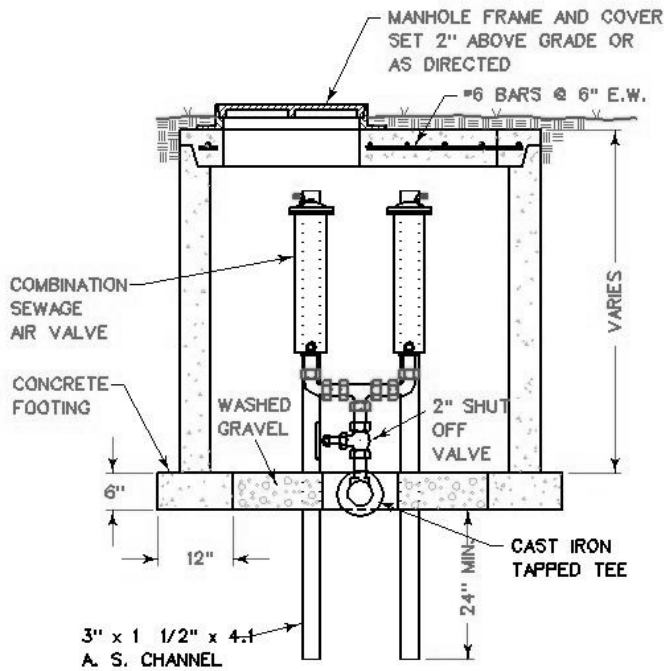

NOTE:
 THE COMBINATION SEWAGE AIR VALVE ASSEMBLY SHALL BE COMPOSED OF A SEWAGE AIR RELEASE VALVE AND A SEWAGE AIR AND VACUUM VALVE. THE SEWAGE AIR RELEASE VALVE SHALL BE VAL-MATIC SERIES 48, APCO SERIES 400 OR EQUAL. THE SEWAGE AIR AND VACUUM VALVE SHALL BE VAL-MATIC SERIES 301, APCO SERIES 401, OR EQUAL.

ILLUSTRATION 4.6.2. – PRESSURE SEWER AIR RELEASE VALVE

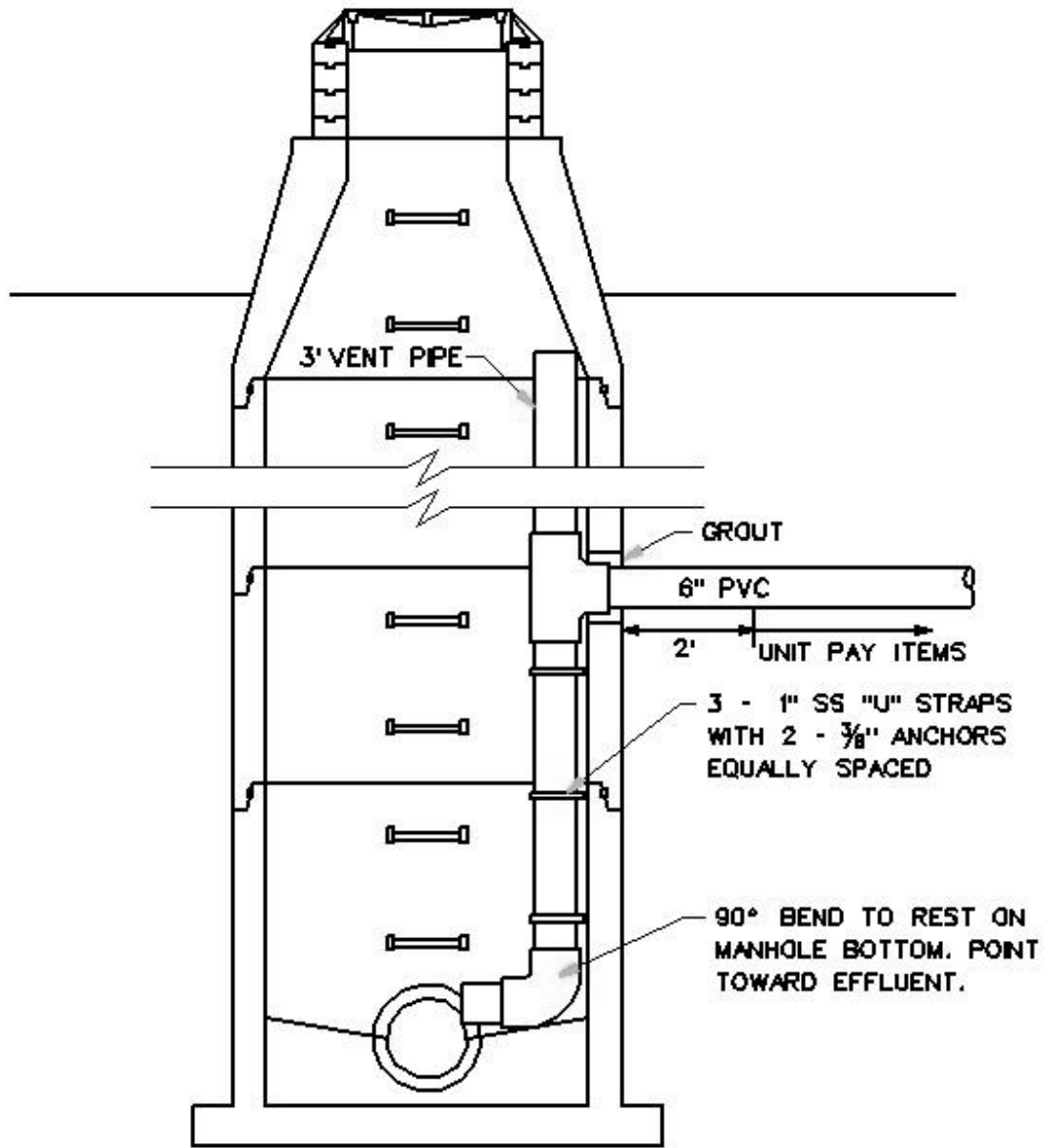

ILLUSTRATION 4.6.3. – PRESSURE SEWER CONNECTION TO EXISTING MANHOLE



PART 7 – GRANULAR MATERIALS

4.7.1. GENERAL

The City shall be furnished certified test reports of the materials and gradations prior to incorporation into the work.

4.7.2. MATERIALS

A. CRUSHED STONE

Crushed stone shall consist of fragments of sound, durable limestone, free from disintegrated stone, salt, alkali, vegetable matter, or adherent coatings and other deleterious substances; and shall be reasonably free from thin or elongated pieces. The percentage of wear shall not exceed fifty percent (50%).

The gradation of the crushed stone shall be as follows:

<u>TYPE</u>	<u>FINE</u>	<u>MEDIUM</u>	<u>COARSE</u>	<u>CRUSHER RUN</u>
<i>Square Opening Sieves</i>				
		<i>Percent Passing, (by weight)</i>		
3 inch	----	----	100	
2 inch	----	----	60-70	
1 ½ inch	----	----	----	100
1 ¼ inch	----	100	5-40	----
1 inch	----	90-100	0-10	90-100
¾ inch	100	20-60	----	----
½ inch	95-100	0-10	----	----
⅜ inch	45-90	----	----	45-74
No. 4	0-15	0-3	----	30-55
No. 16	0-3	----	----	----
No. 100	----	----	----	4-15

4.7.3. SELECT BORROW MATERIAL

Selected Borrow Material shall be a mixture of sand and clay and shall contain sufficient binder material, natural or processed, to produce a uniform mixture complying with the requirements of these specifications. The materials shall be uniform and free of organic matter such as leaves, grass, roots, and other objectionable or foreign substances.

The gradation of the natural or processed material shall be as follows:

<i>Square Opening Sieves</i>	<i>Percent Passing (by weight)</i>
No. 10-----	100
No. 40-----	20 - 100
No. 60-----	15 - 85
No. 200-----	6 - 40

The material shall have a plasticity index not more than six (6) and have a liquid limit of not more than twenty-five (25). (Local clean pit run topping-like material will normally meet this specification.)

WASHED GRAVEL

Washed Gravel shall be composed of hard, tough, durable particles reasonably free of injurious or deleterious substances. The percentage of wear shall not exceed fifty percent (50%).

The gradation and characteristics of the washed gravel shall be as follows:

<i>Square Opening Sieves</i>	<i>Percent Passing (by weight)</i>
2-inch	100
1 ½-inch	90-100
1-inch	80-100
¾-inch	55-100
½-inch	35-80
⅜-inch	12-65
No. 4	5-30
No. 10	0-8

CLAY GRAVEL

Clay Gravel shall be composed of natural or artificial mixtures of aggregates and soil mortar so proportioned as to meet all the requirements as hereinafter specified.



The coarse aggregate (material retained on the No. 10 sieve) shall consist of hard, durable particles of uncrushed gravel and shall be free from vegetable or other deleterious substances. The percentage of wear shall not exceed fifty percent (50%).

The binder portion of the surface material (that portion passing the No. 10 sieve) shall be composed of a natural or artificial mixture of natural quartz sand combined with silt and clay.

The gradation of the coarse aggregate shall be as follows:

<i>Square Opening Sieves</i>	<i>Percent Passing (by weight)</i>
3"	-100
1 ½"	85-100
1"	65-100
½"	35-90
No. 4	30-75
No. 10	30-55

The gradation of the binder material shall be as follows:

<i>Square Opening Sieves</i>	<i>Percent Passing (by weight)</i>
No. 10	100
No. 40	20-90
No. 60	15-80
No. 200	8-40

The binder material shall have a plasticity index of not more than six (6) and have a liquid limit of not more than twenty-five (25).

TESTS

Sampling and testing shall be in accordance with the following standard methods of the AASHTO: Sampling, T-2; Sieve Analysis, T-27; Liquid Limit, T-89; Plasticity Index, T-90.

The loss by abrasion test shall be as specified under AASHTO Test T-96.

PART 8 – SEWER SYSTEM CONSTRUCTION RECORDS

4.8.1. REQUIREMENTS

The following records must be provided prior to approval of the Final Plat or release of the Construction Bond:

- A. A copy of the Mississippi Department of Environmental Quality’s final approval letter.
- B. A certification letter from the developer’s engineer that the improvements were constructed in substantial conformance with the approved construction plans and specifications, accompanied by inspection documentation records and construction inspection photographs. The developer, or his designee, is responsible for maintaining



inspection records to ensure that all improvements were constructed according to approved plans.

- C. RECORD DRAWINGS shall accurately represent the completed construction including locations of service stub outs and appurtenances.
- D. RECORD DRAWINGS of the completed construction shall be provided in both hard copy and electronic formats. Provide four (4) printed sets and two (2) sets on CD or other media in PDF or other acceptable machine-readable file format.
- E. Two (2) copies of the manufacturer's literature necessary for reference in operating and maintaining the facilities including but not limited to manufacturer's product descriptive literature for materials incorporated into the work, operation and maintenance manuals for equipment, warranty related information, etc.
- F. Contact information for the source of supply of basic materials and equipment.
- G. Test results including pressure test, mandrel pull results, and other tests.
- H. Prior to acceptance of the sewer system, the City shall require video records to prove that the system has been installed in accordance with these guidelines. Video recording shall be on DVD format for each manhole-to-manhole segment of gravity sewer keyed to the RECORD DRAWINGS with the location and interior condition of each service connection documented by use of a pan and tilt camera and located by measurement from the downstream manhole. A city representative should be present during all video scoping activity.
- I. Other information as may be requested by the Administrator.

~END OF SECTION~

CHAPTER 5: STREETS

PART 1 – GENERAL REQUIREMENTS

The developer shall be fully responsible for the design, installation, and oversight of any necessary physical improvements to connect to existing public infrastructure.

All streets, whether public or private, should be constructed in accordance with the regulations herein, excepting private driveways serving one (1) residential property.

5.1.1. BLOCKS

- A. The lengths, widths, and shapes of blocks shall be determined with due regard:
 - 1) Building sites that are suitable for the special needs of the uses contemplated;
 - 2) Convenient access, circulation, control, and safety of street traffic;
 - 3) Limitation and opportunities of topography
 - 4) Typical block arrangements should not be more than one thousand (1,000) linear feet in width or depth, or less than two hundred (200) linear feet.

5.1.2. STREET LAYOUT

- A. Streets should be platted along contour elevations which will afford minimum grades and greatest visibility.
- B. The proposed street layout shall be coordinated with the street system of the surrounding area. All streets must provide for the continuation or appropriate projection of principal streets in surrounding areas and provide reasonable means of ingress and egress for surrounding acreage tracts.
- C. Street alignment shall be designed to eliminate sharp curves and street jogs. No street plan will be approved with intersections which offset less than one hundred twenty-five feet (125') between center lines. Streets shall intersect as nearly at right angles as possible and in no case at an angle of less than sixty (60) degrees.
- D. A circular curve is required at any deflection in street alignment. Horizontal curves on collector streets shall have a minimum of a two hundred foot (200') radius computed from the centerline; local streets, a one hundred foot (100') radius.
- E. Dead-end streets will not be approved unless the dead-end street is for the purpose of connecting future development. Cul-de-sac(s) shall not exceed five hundred feet (500') in length and shall terminate in a circle with a radius of not less than forty feet (40') from the back of curb.

In single family residential neighborhoods with a minimum of one-acre lot allowed by zoning, the street length may exceed five hundred feet (500') at the Mayor's discretion, provided that the width of the street is at least thirty four feet (34') from the back of curb to back of curb, or the edge of pavement to edge of pavement. In addition, the circle of termination must have a radius of at least fifty feet (50') from



the back of curb. If these requirements are met, the street shall be no longer than fifteen hundred feet (1,500') in length.

- F. Street corners shall have a radius of not less than ten feet (10') at the property line and not less than fifteen feet (15') at the curb line on residential streets. Curb radii connecting into collector streets shall have radius of not less than twenty-five feet (25').
- G. Street grades on local streets shall comply with good engineering practices and shall not exceed ten percent (10%) or be less than point four percent (0.4%). Street grades of collector streets shall not exceed eight percent (8%).
- H. Street grades approaching intersections shall not exceed six percent (6%) for a distance of not less than one hundred feet (100') from the center line of said intersection.
- I. Street names for all subdivision plats shall be subject to approval by the City.
- J. Subdivision names for plats shall be subject to approval by the City and shall not duplicate the name of any plat already used.
- K. Intersections shall be designed to provide safe stopping sight distances.
- L. The location of street and security lighting standards shall be coordinated with the power company and shall be indicated on the drawings.
- M. Vertical Clearance: The minimum vertical clearance at underpasses for new and reconstructed bridges shall be fourteen (14) feet over the entire roadway, with an additional six (6) inches allowed for future resurfacing, i.e., the total vertical clearance is fourteen feet six inches (14', 6"). Where existing bridges will remain in place, the minimum vertical clearance is fourteen (14) feet. For structures over railroads, the minimum vertical clearance between the top of rail and bottom of the roadway structures is twenty-three (23) feet.

5.1.3. STREET DESIGN STANDARDS

A. All streets must be classified as to their functional classification and this classification must be shown on the subdivision plat and on the construction plans. The following classifications shall be used.

- (1) Collector Streets: A roadway classified as a collector normally provides better traffic circulation than local streets. They serve residential, commercial, and industrial areas. This type of roadway collects traffic from local streets.
- (2) Local Streets: Local streets provide access to abutting lands and allow local traffic to gain access to the collector streets. Local streets offer the lowest level of mobility and through traffic is discouraged on these streets.

B. Street widths shall not be less than:

		Pavement (Back to Back of Curb)
(1)	Collectors	60 feet
(2)	Local Streets	50 feet
(3)	Local (R-4 & 5)	50 feet
(4)	with Cul-du-Sac (>500 feet)	50 feet

These dimensions are minimum requirements. If required by traffic volume and/or classification, the streets shall be designed to requirements set forth in the publication entitled "A Policy on Geometric Design of Highways and Streets", latest edition, prepared by the American Association of State Highway and Transportation Officials (AASHTO).

C. Streets must be paved and constructed with MDOT Type "1" (Modified) or MDOT Type "2" (Modified) combination curb and gutter with adequate drainage structures and appurtenances.

D. Local streets in subdivisions located in A-1 and R-1 zones may be allowed to have open ditch drainage with no curb. However, if this layout is selected, the road design must feature a minimum fifteen-foot (15') utility easement to be located parallel along both sides of the right-of-way line. At the same time, the minimum shoulder width on ditch section roads should be no less than four feet (4').

E. **All streets shall be structurally designed and constructed to meet or exceed the Street Design Standards outlined in the *Roadway and Street Storm Drainage Construction Standards for Sub-divisions*, as adopted by the Lee County Board of Supervisors, and amended periodically.** All new streets shall be constructed to have a base course of six inch (6") crushed stone and surface course consisting of three inch (3") thick hot mix bituminous asphalt in lifts. **DBST is not an acceptable material for paving streets within City limits.**

During the installation of the road base and the road way, an onsite inspection by the mayor or the public works director will be required to ensure that the standards are met.

Crushed limestone: SN = 0.14 per inch depth

Parent surface course: SN = 0.44 per inch depth

F. All street materials and construction methods shall conform to requirements set forth in the Mississippi Standard Specifications for State Aid Road and Bridge Construction (2004 Edition).



Note: For structural concrete and hot plant bituminous pavement mixes, testing shall be in accordance with the Mississippi Standard Specifications for State Aid Road and Bridge Construction.

- G. Pavement slope from centerline to edge of pavement should be two percent (2%). Radii of pavement at intersections shall be a minimum of twenty-five feet (25').
- H. All subgrade material in excavated sections must be inspected and proof-rolled to insure its stability. Any unstable sections must be removed and replaced with suitable materials. All subgrade material in embankment sections must be placed in lifts not to exceed twelve inches (12") thick and compacted to at least ninety-five percent (95%) of its maximum standard proctor density within two percent of its optimum moisture content.
- I. The base materials shall be compacted to at least ninety-five percent (95%) of its maximum standard proctor density within two percent (2%) of its optimum moisture content. Furnish roadway subgrade density test results. Any laboratory tests required establishing the specified quality of materials used, or densities of base course construction shall be performed by a reputable commercial testing laboratory at the developer's expense.
- J. All signage, marking, and striping for public streets shall conform to recommendations set forth in the Manual on Uniform Traffic Control Devices for Streets and Highways (MUTCD) as adopted by the Federal Highway Administration and amended periodically.
- K. The developer shall submit test reports covering the materials incorporated in the work. Test reports must be stamped and signed by the developer's engineer.

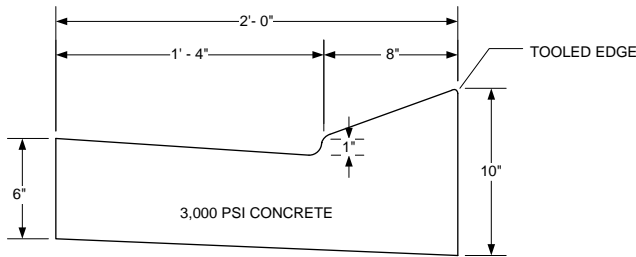

**MDOT TYPE "2" (MODIFIED)
COMBINATION CURB & GUTTER**

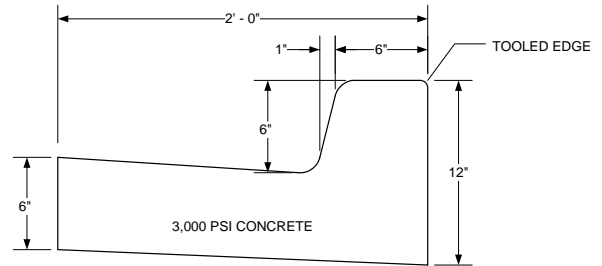

**MDOT TYPE "1" (MODIFIED)
COMBINATION CURB & GUTTER**

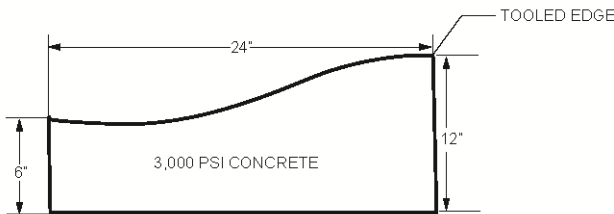

COMBINATION ROLL CURB & GUTTER

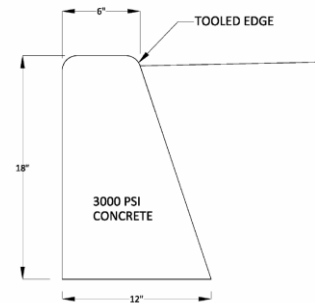

FLUSH-MOUNT ALLEY CURB

ILLUSTRATION 5.1.2. – CURB AND GUTTER DETAILS

5.1.4. SIDEWALK DESIGN STANDARDS

- A. The developer shall be responsible for the installation of sidewalks parallel to the street in the public right-of-way as required by the Zoning Ordinance.
- B. Sidewalks shall be a minimum of five feet (5') wide by four inches (4") thick with wire mesh for reinforcement.
- C. Expansion joints shall be located where sidewalk abuts concrete driveways, curb or other adjacent structures.
- D. One inch (1") deep contraction joints shall be placed at intervals of approximately fifteen feet (15') or at a spacing that matches the adjacent curb.
- E. Formed contraction joints shall be finished with a tool having a one quarter inch (1/4) radius.
- F. Scored joints shall be one quarter inch (1/4") deep and place at the spacing indicated for the width of sidewalk or match scored joints of adjacent curb.
- G. Concrete shall be finished by means of a float, steel troweled, and broomed with a fine brush in a transverse direction, or may have custom finish if approved in site plans.



- H. One quarter inch (1/4") deep scored joints should be typically spaced at six feet (6') or equal to sidewalk width.
- I. All sidewalks must be complete no later than five (5) years from the approval of the final plat.
- J. No Certificate of Occupancy will be granted until the required sidewalk is complete for a specific property.
- K. Sidewalks must be compliant with Americans with Disabilities Act Accessibility Guidelines (ADAAG).

PART 2 – STREET CONSTRUCTION RECORDS

5.2.1. REQUIREMENTS

The following records must be provided prior to approval of the Final Plat or release of the Construction Bond.

- A. A certification letter from the developer's engineer that the street improvements were constructed in substantial conformance with the approved construction plans and specifications. The developer is responsible for providing construction as-built records and construction photographs to document that all improvements were built according to the approved plans.
- B. RECORD DRAWINGS of the completed construction shall be provided in both hard copies and electronic formats. Provide four (4) printed sets and two (2) sets on CD or other media in PDF or other acceptable machine-readable file format.
- C. RECORD DRAWINGS shall accurately represent the completed construction including the location, lengths, type, and thickness gauge or class of storm sewers and appurtenances.
- D. Other information as may be required otherwise or requested by the Administrator.

~END OF SECTION~



CHAPTER 6: UTILITY DEEDS AND EASEMENTS

PART 1 – GENERAL MINIMUM REQUIREMENTS

- A. Where a water line, sanitary sewer line, manhole, lift station, or other appurtenance is located outside of the street right-of-way, utility easements shall be indicated on the subdivision plat.
- 6" Easements measuring seven and a half feet (7-1/2') each way from the centerline to the pipe for a total of fifteen feet (15') shall be provided and shown on the development plans. The developer shall provide for City of Saltillo access to manhole, water lines, sanitary sewer lines, or lift stations for the purpose of extending lines for future developments; not to overlap building setbacks, or be within the buildable area for residential developments. Any pipe deeper than six feet in depth shall have an additional four feet of width add to the easement. (Two feet of easement on each side of pipe.) In addition, two feet of easement for each foot of depth beyond six feet of depth shall be required. Pipes larger than twenty-four (24") inches in diameter shall have their size plus four feet (4) added to the width of the easement.
- C. Easements measuring seven and a half feet (7-1/2') each way from the property line for a total of fifteen feet (15') shall be provided along all rear and side lot lines for proposed and future utility access.
- D. A deed shall be provided to the City of Saltillo for each lift station site along with a written description of the access easement. The size of the deeded land shall be the discretion of the City, twenty-five feet by twenty-five feet (25' x 25') minimum.
- E. Proper easements must be recorded for all sewer lift stations and stormwater detention/retention ponds. These easements must be located in privately maintained greenspace of the associated site.
- F. Within residential subdivisions, sanitary sewer and/or water easements are not permitted within the buildable area of any lot, but may overlap any area of a lot being within a building setback. Easements should be allocated to the edges of properties whenever possible. Easements are not encouraged across lots.
- G. The easement for storm drain pipes and pipe culverts should be proportional in width to both the depth and the diameter of the pipe. The easement must be as wide as the deepest portion of the pipe. The easement width should be rounded up in five foot (5') increments. The Public Works Director must first approve the size of the easement prior to construction and installation.
- H. Any easement over five feet (5') in depth must first be approved by the mayor or by the public works director based on the size and width.

PART 2 – MONUMENTS

- 5" Monuments, or markers, shall be placed at all corners or changes in alignment along the boundary of the subdivision and at all block corners, angle points, or curves in street right-of-way boundary lines.
- 6" These monuments, or markers, shall consist of a single eighteen-inch (18") long, one-half (1/2") inch diameter steel rod.